



VERSA MANUAL

MANUAL #NTCW

REVISION SHEET FOR MANUALNTCW

Release No.	Date	Revision Description
1	07/13/20	Initial design/release of MANUALNTCW
2	05/12/21	Stainless Steel Update
3	07/14/21	1250 tool cup added/12ga. wiring/Battery warning update
4	08/23/21	Versa II Battery added
5	01/18/23	Envoy and Safety updates

NOTE: Specifications and parts are subject to change without notice

Kaivac, Inc.
 2680 Van Hook Ave.
 Hamilton, OH 45015



Do not attempt to operate the machine before reading and understanding the manual. Pay close attention to all WARNINGS, CAUTIONS and NOTES. Failure to do so may cause serious injury and extensive machine damage

OPERATOR & PARTS MANUAL - TABLE OF CONTENTS

1.0 Getting Started

1.1	PRODUCT IDENTIFICATION	5
1.2	WARRANTY REGISTRATION	5
1.3	SAFETY PRECAUTIONS: CORDED UNITS ONLY.....	6
1.3	SAFETY PRECAUTIONS: CORDED (CONTINUED)	7
1.4	SAFETY PRECAUTIONS: BATTERY UNITS ONLY	8
1.4	SAFETY PRECAUTIONS: BATTERY UNITS ONLY (CONTINUED)	9
1.5	BATTERY INFORMATION.....	10
1.6	GROUNDING INFORMATION	11
1.6	GROUNDING INFORMATION (CONTINUED)	12
1.7	LIMITED WARRANTY PROTECTION PLAN	13

2.0 Setup/ Assembly

2.1	TOOL ARRANGEMENT.....	14
2.2	PREPARATION FOR USE.....	15
2.2	PREPARATION FOR USE (CONTINUED).....	16
2.2	PREPARATION FOR USE (CONTINUED).....	17
2.3	FILLING THE UNIT	18
2.4	EMPTYING VACUUM TANK.....	18
2.5	BATTERY USE	19

3.0 Maintenance

3.1	MACHINE MAINTENANCE	20
3.2	VACUUM DIAGRAM	21
3.3	PUMP DIAGRAM	22
3.4	1200 AC/CORDED ELECTRICAL DIAGRAM	23
3.5	17/2700 AC/CORDED ELECTRICAL DIAGRAM.....	23
3.6	1200 QC POWER PACK ELECTRICAL DIAGRAM.....	24
3.7	17/2700 QC POWER PACK ELECTRICAL DIAGRAM.....	25

4.0 Troubleshooting and Upkeep

4.1	TROUBLESHOOTING	26
4.2	TROUBLESHOOTING (CONTINUED).....	27
4.3	TROUBLESHOOTING (CONTINUED).....	28
4.4	TROUBLESHOOTING TIPS	29
4.5	REPLACEMENT (MONTHLY)	29

5.0 Parts Diagrams and Specifications

5.1	1200 VAC TANK ASSEMBLY.....	30
5.2	1200 WATER TANK ASSEMBLY.....	30
5.3	1250 BLACK BOX ASSEMBLY	31
5.4	1250 QC BLACK BOX ASSEMBLY.....	32
5.5	1200 SWITCH PANEL ASSEMBLY	33
5.6	1200 QC SWITCH PANEL ASSEMBLY	33
5.7	1200 VALVE ASSEMBLY.....	33
5.8	1250 PUMP ASSEMBLY	34
5.9	1250 QC PUMP ASSEMBLY	34
5.10	1200 QC VAC MOTOR ASSEMBLY	35
5.11	1200 VAC MOTOR ASSEMBLY	35
5.12	17001 VAC TANK ASSEMBLY.....	36
5.13	17001 WATER TANK ASSEMBLY	36
5.14	17501 PUMP ASSEMBLY.....	37
5.15	17001 VAC MOTOR ASSEMBLY	37
5.16	27001 VAC TANK ASSEMBLY.....	38
5.17	27001 WATER TANK ASSEMBLY.....	38
5.18	27501 PUMP ASSEMBLY.....	39
5.19	27001 VAC MOTOR ASSEMBLY	39
5.20	17501 AC BLACK BOX ASSEMBLY	40
5.21	QC POWER PACK BLACK BOX ASSEMBLY	41
5.22	17001 SWITCH PANEL ASSEMBLY	42
5.23	17501 BATTERY SWITCH PANEL ASSEMBLY.....	42
5.24	17001/27001 VALVE ASSEMBLY	43
5.25	HEPA ASSEMBLY.....	43

1.1 PRODUCT IDENTIFICATION

Identify your system below to see the correct manual pages for your product.

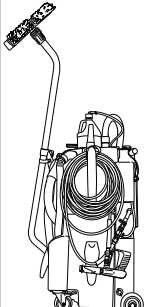

1250 (CORDED)
ASSOCIATED PAGES:
 PG. 22-23
 PG. 30-35

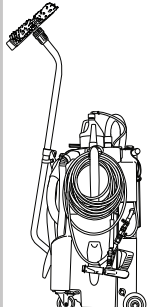

1250(BATTERY)
ASSOCIATED PAGES:
 PG. 22
 PG. 24
 PG. 30-35

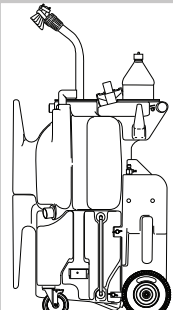

1700 (CORDED)
ASSOCIATED PAGES:
 PG. 22-23
 PG. 30-31
 PG. 40
 PG. 42-43

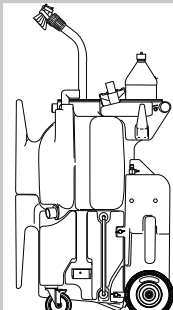

1700 (BATTERY)
ASSOCIATED PAGES:
 PG. 25
 PG. 36-37
 PG. 42-43

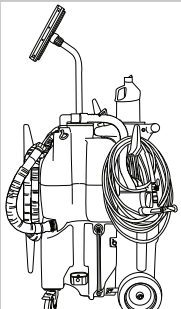

2700 (CORDED)
ASSOCIATED PAGES:
 PG. 22-23
 PG. 32-33
 PG. 38-39

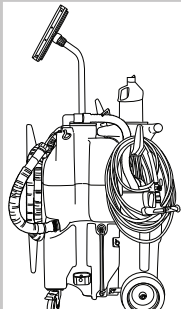

2700 (BATTERY)
ASSOCIATED PAGES:
 PG. 25
 PG. 38-39
 PG. 41

1.2 WARRANTY REGISTRATION

Thank you for purchasing a Kaivac product. Please take a few moments to register your product at kaivac.com/warranty.

Why register?

- Ensure your warranty coverage
- Simplify warranty service in the future with your information on file
- Be the first to know about upgrades, issues, new options and special offers.

1.3 SAFETY PRECAUTIONS: CORDED UNITS ONLY

IMPORTANT SAFETY INSTRUCTIONS — SAVE THESE INSTRUCTIONS

READ ALL INSTRUCTIONS BEFORE USING (THIS APPLIANCE)

When using an electrical appliance, basic precautions should always be followed, including the following:



To reduce the risk of fire, electric shock, or injury:

- Turn off the unit before unplugging. Do not leave appliance when plugged in. Unplug from outlet when not in use and before servicing.
- Connect to a properly grounded outlet only. Do not remove ground pin. See Grounding Instructions below.
- DO NOT allow to be used as a toy. Close attention is necessary when used by or near children.
- Use only as described in this manual. Use only manufacturer's recommended attachments.
- Inspect cord prior to use. Do not use with damaged cord or plug. If appliance is not working as it should, has been dropped, damaged, left outdoors or dropped into water, return it to a service center.
- DO NOT handle plug or appliance with wet hands.
- DO NOT pull or carry by cord, use cord as handle, close a door on cord, or pull cord around sharp edges or corners. Do not run appliance over cord. Keep cord away from heated surfaces.
- DO NOT unplug by pulling on cord. To unplug, grasp the plug, not the cord.
- DO NOT put any object into openings. Do not use with any opening blocked; keep free of dust, lint, hair, and anything that may reduce air flow.
- Keep hair, loose clothing, fingers, and all parts of body away from openings and moving parts. Turn off all controls before unplugging.
- Use extra care when cleaning on stairs.
- DO NOT use to pick up flammable or combustible liquids such as gasoline, or use in areas where they may be present.
- DO NOT pick up anything that is burning or smoking, such as cigarettes, matches or hot ashes.
- If using extension cord with appliance, make sure the connection is above the floor and away from exposure to liquid.
- Keep all connections dry and off the ground.
- To reduce the risk of injury, close supervision is necessary when a product is used near children.
- Stay alert - watch what you are doing.
- Keep operating area clear of all persons.
- The Kaivac shall be disconnected from mains during cleaning or maintenance and when replacing parts or converting the machine to another function.
- DO NOT overreach or stand on unstable support. Keep good footing and balance at all times.
- DO NOT operate without the float installed. If float is removed, reinstall by screwing back into place.
- Keep the cord away from heated surfaces.
- DO NOT use without dust bag and/or filters in place.
- This product comes with a grounded attachable extension cord. If damaged, replace with equivalent cord. This cord must be attached and mechanically secured using the provided cord connector to use the equipment.
- DO NOT operate the product when fatigued or under the influence of alcohol or drugs.
- Know how to stop the product and bleed pressures quickly. Be thoroughly familiar with the controls.
- Follow the maintenance instructions specified in the manual.

SPRAY SYSTEM WARNINGS (ONLY):

- DO NOT spray liquid from the Kaivac onto electrical outlets or any electrical devices.
- Risk of injection or injury to persons - DO NOT direct discharge stream at persons.
- INJECTION HAZARD: Equipment can cause serious injury if the spray permeates the skin. Do not point the gun at anyone or any part of the body. In case of permeation, seek medical aid immediately.
- THIS SYSTEM IS CAPABLE OF PRODUCING 500 PSI (3447 kPa). To avoid rupture and injury, do not operate this pump with components rated less than 500 PSI (3447 kPa) working pressure (including but not limited to spray guns, hose, and hose connections); and before servicing, cleaning or removal of any part, shut off power and relieve pressure.

1.3 SAFETY PRECAUTIONS: CORDED (CONTINUED)

- High pressure cleaners shall not be used by children, persons with reduced physical, sensory or mental capabilities or lack of experience and knowledge or untrained personnel. Children shall not play with the appliance. Cleaning and user maintenance shall not be made by children without supervision.
- This product may also have been provided with a ground fault circuit interrupter built into the power cord. If replacement of the plug or cord is needed, use only identical replacement parts.
- Test the ground fault circuit interrupter (GFCI) before each use.
- **Personal Protective Equipment (PPE): It is recommended to wear proper personal protective equipment as required by the chemical product label instructions used in conjunction with the appliance.**

FOR INDOOR USE ONLY

INTENDED FOR COMMERCIAL USE



To Reduce the Risk of Electric Shock — Do not expose to rain or water. Store indoors.

1.4 SAFETY PRECAUTIONS: BATTERY UNITS ONLY

IMPORTANT SAFETY INSTRUCTIONS — SAVE THESE INSTRUCTIONS

READ ALL INSTRUCTIONS BEFORE USING (THIS APPLIANCE) IMPROPER USE OF PRODUCT CAN RESULT IN SERIOUS INJURY.

When using an electrical appliance, basic precautions should always be followed, including the following:



To reduce the risk of fire, electric shock, or injury:

General Warnings:

- For commercial or residential use.
- DO NOT allow to be used as a toy. Close attention is necessary when used by or near children.
- Use only as described in this manual. Use only manufacturer's recommended attachments.
- Keep hair, loose clothing, fingers, and all parts of body away from openings and moving parts.

Battery/Electrical Warnings:

- ONLY USE with Kaivac, Inc. battery, and charger, CHARG36V series.
- Use appliance only with specifically designated battery packs. Use of any other battery packs may create a risk of injury of fire.
- When charging, make sure charger has at least 6 inches of clearance on all sides for adequate air flow.
- DO NOT charge batteries outdoors.
- DO NOT attempt to repair, service or modify the batteries or charger. Contact Kaivac Technical Support with any issues.
- DO NOT short-circuit the battery or charger terminals with conductive items such as paper clips. This can deliver high current, resulting in heat and fire.
- Keep sparks and flames away from batteries.
- DO NOT crush, drop, incinerate or damage the Battery. Do NOT use a Battery that has been damaged in any way. DO NOT incinerate the battery even if it is non-working or severely damaged. The battery can explode in a fire.
- DO NOT expose a Battery or appliance to fire or excessive temperature. Exposure to fire or temperature above 265°F (130°C) may cause explosion.
- DO NOT use or store the NTC System or Battery in refrigerated areas, in environments when the battery is in direct contact with liquids, or near flammable or combustible materials.
- DO NOT charge or store Battery for extended time (1 month or more) in temperatures below 40°F (4°C).
- If fumes smelled from battery, discontinue use immediately, place inside a metal canister in a well-ventilated area.
- Prevent unintentional starting. Ensure the switch is in the off-position before connecting to battery, picking up or carrying the appliance. Carrying the appliance with your finger on the switch, or energizing an appliance that has the switch on invites accidents.
- Disconnect the battery from the appliance before making any adjustments, changing accessories, or storing appliance. Such preventive safety measures reduce the risk of starting the appliance accidentally.
- When battery is not in use, keep it away from other metal objects like paper clips, coins, keys, nails, screws or other small metal objects that can make a connection from one terminal to another. Shorting the battery terminals together may cause burns or a fire.
- Under abusive conditions, liquid may be ejected from the battery; avoid contact. If contact accidentally occurs, flush with water. If liquid contacts eyes, additionally seek medical help. Liquid ejected from the battery may cause irritation or burns.
- Do not use a battery or appliance that is damaged or modified. Damaged or modified batteries may exhibit unpredictable behavior resulting in fire, explosion or risk of injury.
- If unit is smoking or sparking, move outside to a fire-safe location immediately. If possible, disengage battery from unit, notify management, and call Kaivac Technical Support at 800-287-1136.

Charger/Electrical Warnings:

- Connect charging cord to a properly grounded outlet only. See Grounding Instructions.
- DO NOT plug in Charger while Vacuum Head is in ON position. It may damage the system.
- Follow all charging instructions and do not charge the battery or appliance outside of the temperature range specified in the instructions. Charging improperly or at temperatures outside of the specified range may damage the battery and increase the risk of fire.
- DO NOT leave charger plugged in when not in use.
- DO NOT operate charger if it has received a sharp blow, been dropped, or damaged in any way.
- DO NOT use charger if it has a damaged cord or plug. DO NOT carry charger by cord.
- DO NOT pull on charger cord to unplug. Grasp and pull the plug, not the cord.
- DO NOT handle charger, including charger plug and charger terminals, with wet hands while charger is plugged in or while inserting plug into electrical outlet.

1.4 SAFETY PRECAUTIONS: BATTERY OPERATED (CONTINUED)

Vacuum and operation warnings:

- NO COMBUSTIBLES! Sparks inside the motor can ignite flammable vapors or dust. Do not use near combustible liquids and gases, or to pick up explosive dusts or gasoline. Do not pick up anything that is burning or smoking such as cigarettes or hot ashes.
- DO NOT plug Battery in while Vacuum Motor is in ON position. It may damage the system.
- CHECK FLOAT on Vacuum Motor and clean before each use. Clogged screen may lead to loss of suction.
- DO NOT put any object into openings. Do not use with any opening blocked; keep free of dust, lint, hair and anything that may reduce air flow.
- Use extra care when cleaning on stairs.
- DO NOT use without Vacuum Motor Float Cage in place.

SPRAY SYSTEM WARNINGS (ONLY):

- Do not spray liquid from the Kaivac onto electrical outlets or any electrical devices.
- Risk of injection or injury to persons - do not direct discharge stream at persons.
- INJECTION HAZARD: Equipment can cause serious injury if the spray permeates the skin. Do not point the gun at anyone or any part of the body. In case of permeation, seek medical aid immediately.
- This system is capable of producing 500 PSI (3447 kPa). To avoid rupture and injury, do not operate this pump with components rated less than 500 PSI (3447 kPa) working pressure (including but not limited to spray guns, hose, and hose connections); and before servicing, cleaning or removal of any part, shut off power and relieve pressure.
- High pressure cleaners shall not be used by children, persons with reduced physical, sensory or mental capabilities or lack of experience and knowledge or untrained personnel. Children shall not play with the appliance. Cleaning and user maintenance shall not be made by children without supervision.

QUICK RELEASE INSTRUCTIONS

1. To disconnect the motor from the Power Pack, push the button on the electrical connector and pull toward you to disengage the motor electrical cord from the Power Pack.
2. Then to remove the Battery from the unit, while standing at the rear of the unit, grab the Battery by the handle and lift it up away from the unit.
3. To reconnect the Power Pack to the motor, insert the motor electrical connector into the Battery Pack outlet, aligning the key features of the electrical connector into the outlet key-way. Press the connector into the outlet until it clicks to lock into place.

Personal Protective Equipment (PPE): It is recommended to wear proper personal protective equipment as required by your Chemical product label instructions used in conjunction with the appliance. Refer to the Kaivac label on Kaivac chemical products.



WARNING To Reduce the Risk of Electric Shock — Do not expose to rain or water.
Store indoors.

1.5 BATTERY INFORMATION

Keep Batteries at Room Temperature: Store between 32 and 113 degrees F (0°C to 45°C). Avoid battery exposure to extreme temperatures. If shelving battery longer than (1) month, then deplete battery to 50% charge (two bars on the battery indicator).

Batteries Lose Capacity Over Time: Batteries naturally deteriorate over time whether being used or not. If battery use instructions are properly followed, batteries deteriorate at a rate of 10% run time per year.

Fully Discharge vs. Partial Discharge and the Effect on Battery Cycles: Unlike lead acid batteries typically used in auto scrubber, the Kaivac Battery is not damaged by fully discharging. The BMS (Battery Management System) has a cutoff voltage of 30V which protects the Battery from experiencing full discharge. Running the Battery to full discharge will reduce the amount of charge cycles. The expected hours of use are approximately 600 hours. For example, if running to full discharge, you would expect 400 cycles. If you run to 80% discharge, then you would expect to get more cycles (500 cycles). With dual batteries make sure to alternate batteries per charge for full life capacity.

Extended Storage: It is recommended to discharge to 50% capacity (two bars on the battery indicator) and store in a cool location (between 32°F to 113°F or 0°C to 45°C). To avoid battery impact, store battery laying down on its side on lowest shelf, and secured. If battery is dropped or experiences an impact, discontinue use and replace. Using a damaged battery can result in damage to the unit.

Battery Gauge: The Kaivac Batteries come with a built-in Battery Gauge or “Fuel Gauge” which shows the approximate run time for the current charge remaining.

Disposal: Rechargeable batteries eventually wear out. When your Kaivac Battery run time is less than 55% (i.e. 50 minutes for non-quick change and 33 minutes for Quick Change batteries), then we recommend replacing your battery.

WARNING DO NOT DISCARD BATTERY INTO TRASH! Doing so can lead to a fire. It is important to recycle your old batteries at your local recycling facility or by calling 1-800-USA-CLEAN (1-800-872-2532) and selecting Option 3.

Battery Specifications	
Weight	With Box, 11 lbs. (4,9 kg)
Body Material	Injection Mold Polypropylene
Dimensions (H x W x D)	18 x 7 x 6 in. (45,7 x 17,8 x 12,7 cm)
Voltage	36V DC
Battery Capacity	15 A-hr
Battery Current	15 A DC
Battery Type	Lithium-Ion
Approx. Run Time BOL (Beginning of Life)	64 minutes
Approx. Run Time EOL (End of Life)	35 minutes (discontinue use and take to recycling center)
Battery Box Receptacle	IP65 / IP67 (not required for UL)
Run Time Hour Meter	Acts as “odometer for battery” and runs only when motor switch is ON
Approx. Charge Cycles	400 @ 100% discharge / 500 @ 80% discharge
Cut off Voltage (fully discharged)	30V
Charger Specifications	
Approx. Charge Time	6 hours
Charger Amps	4 Amps
Charge Voltage	42V DC
Charger Voltage	110-240VAC / 36VDC (240VAC version only needs correct plug for wall outlet)
Charging Robustness	No special instructions
Battery Charge Memory	None
Battery Charge Gauge	Yes, LED Indicator
Approx. Charge Cycles	400 @ 100% discharge / 500 @ 80% discharge
Storage/Inventory:	
Storage & Operation Ambient Temp	32°F (0°C) to 80°F(27°C)
Storage & Shipping Charge	40-60% Charge (35-38VDC)

1.6 GROUNDING INFORMATION

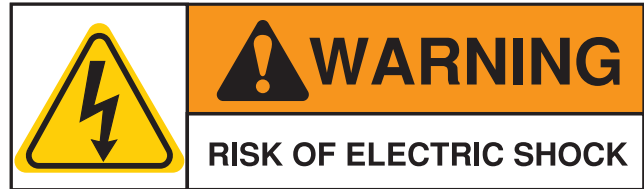

Grounding: Corded Units

GROUND FAULT CIRCUIT INTERRUPTER PROTECTION *(for spray systems only)*

This machine was supplied with a ground-fault circuit-interrupter(GFCI) built into the plug of the power-supply cord. This device provides additional protection from the risk of electric shock. Should replacement of the plug or cord become necessary, use only identical replacement parts that include GFCI protection.

This appliance is for use on a nominal circuit and has a grounding attachment plug. Make sure that the appliance is connected to an outlet having the same configuration as the plug. No adapter should be used with this appliance.

GROUNDING INSTRUCTIONS

This product must be grounded. If it should malfunction or breakdown, grounding provides a path of least resistance for electric current to reduce the risk of electric shock. This product is equipped with a cord having an equipment-grounding conductor and a grounding plug. The plug must be plugged into an appropriate outlet that is properly installed and grounded in accordance with all local DOE and ordinances.



Improper connection of the equipment-grounding conductor can result in a risk of electric shock. Check with a qualified electrician or service person if you are in doubt as to whether the outlet is properly grounded. Do not modify the plug provided with the appliance – if it will not fit the outlet have a proper outlet installed by a qualified electrician.

This product comes with a grounded attachable extension cord. If damaged, replace with Kaivac® (OEM) cord, or if necessary an equivalent cord rated 120V, 15 amps, 3-wire, 14 GA. This cord must be attached and mechanically secured using the provided cord connector to use the equipment.

Grounding: Battery Units

GROUNDING INSTRUCTIONS

The charger must be grounded. If it should malfunction or breakdown, grounding provides a path of least resistance for electric current to reduce the risk of electric shock. This appliance is equipped with a cord having equipment grounding conductor and grounding plug. The plug must be inserted into an appropriate outlet that is properly installed and grounded in accordance with all local codes and ordinances.



Improper connection of the equipment-grounding conductor can result in a risk of electric shock. Check with a qualified electrician or service person if you are in doubt as to whether the outlet is properly grounded. Do not modify the plug provided with the appliance – if it will not fit the outlet; have a proper outlet installed by a qualified electrician.

This appliance is for use on a nominal circuit and has a grounding attachment plug. Make sure that the appliance is connected to an outlet having the same configuration as the plug. No adapter should be used with this appliance.

1.6 GROUNDING INFORMATION (CONTINUED)

Make sure your extension cord is in good condition and is the correct size for your appliance. Table 1 shows the correct size to use depending on cord length and nameplate ampere rating. If in doubt, use the next heavier gage. The smaller the gage number, the heavier the cord. An undersized extension cord will cause a drop in line voltage resulting in loss of power and overheating.

Use only three-wire outdoor extension cords that have three-prong grounding receptacles that accept the appliance's plug.

! WARNING To reduce the risk of personal injury due to a loose electrical connection between the appliance's plug and extension cord, firmly and fully attach the appliance plug to the extension cord. Periodically check the connection while operating to ensure it is fully attached. Do not use an extension cord that provides a loose connection. A loose connection may result in overheating, fire, and increases the risk of a burning.

To reduce the risk of disconnection of the appliance cord from the extension cord during operations:

- Make a knot as shown in Figure 1 below:

Figure 1 - Method of securing the appliance cord to the extension cord set

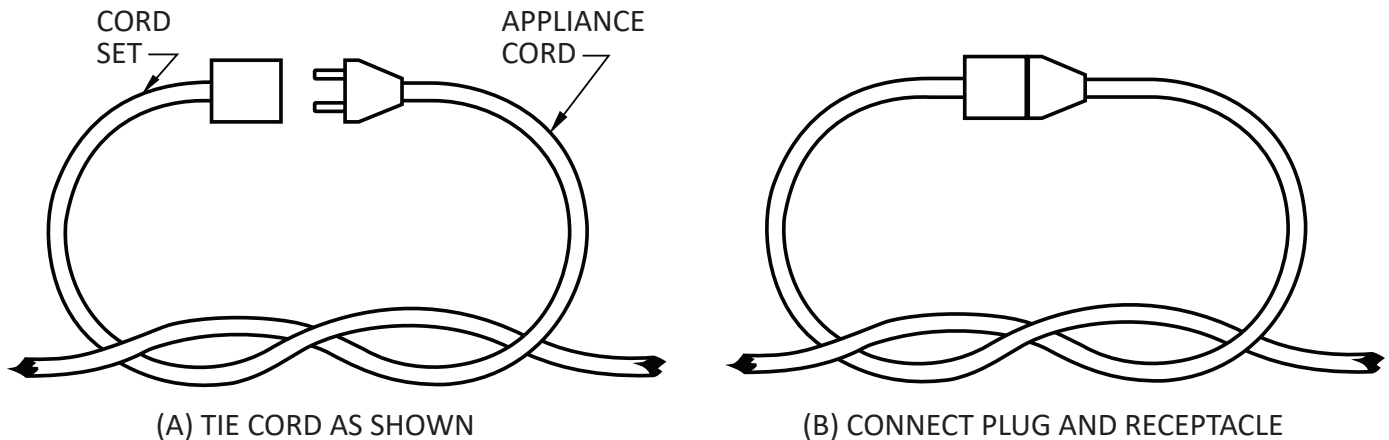

Table 1 - Minimum gauge for extension cords

Ampere rating		Volts	Total length of cord			
			7.62 m (25 ft)	15.24 m (50 ft)	30.48 m (100 ft)	45.72 m (150 ft)
More than, A	Not more than, A	120 V	mm ² (AWG)			
0	6	—	0.82 (18)	1.3 (16)	1.3 (16)	2.1 (14)
6	10	—	0.82 (18)	1.3 (16)	2.1 (14)	3.3 (12)
10	12	—	0.82 (18)	1.3 (16)	2.1 (14)	3.3 (12)

1.7 LIMITED WARRANTY PROTECTION PLAN

The Kaivac has been engineered and tested to provide long lasting performance. This warranty covers defects in workmanship or materials under normal use and service from the date of purchase.

Kaivac, Inc. warrants the following components to be free from defects in materials and workmanship for these time periods:

1. Extended Warranty for end users who use only Kaivac chemicals for the life of the machine.
 - 5 years on rotationally molded parts
 - 3 years on other parts (excluding wear items)
 - 1 year on labor
2. Standard Warranty (for approved non-Kaivac chemicals)
 - 1 year parts and labor
3. Chemicals that have not been approved by Kaivac (If uncertain, please contact Kaivac to verify your chemical before using).
 - No warranty

Battery Program Details

- Battery Warranty covers 2 years on a defective Battery.
- Battery Warranty covers the replacement of the Battery unit.
- Battery replacement remains under Warranty only for the remaining Warranty period of the original Battery unit (for a maximum of 2 years from the date of purchase of the machine).

WARRANTY LIMITATIONS:

- This warranty does not assume responsibility for damage or faulty performance caused by misuse or abuse, or where repairs or modifications have been made or attempted. Kaivac will make the final determination on whether the damage falls under this limited warranty for manufacturer's defects.
- The following actions constitute misuse or neglect of the battery that void the warranty of the battery:
 - Any modifications to Kaivac equipment may nullify any warranty
 - Improper installation of the Quick Change battery
 - Exposure to temperatures above and below the battery limits
 - Use of any charger besides the supplied Kaivac® charger
 - Dropping the battery box
 - Long term storage of the battery without maintaining a battery charge of 25 to 40% capacity
- Under no circumstances will Kaivac be liable for any loss, damage, expenses or consequential damages arising in connection with the use or inability to use Kaivac's product. This warranty is in lieu of any other warranty expressed or implied, including any warranty of merchantability or fitness for a particular purpose.

All Kaivac replacement parts are guaranteed for 90 days from the date of installation. Normal wear items such as wheels, hoses, seals, gaskets, cords, casters, squeegees and GFCI are excluded from warranty coverage.

All warranty claims must be accompanied by a Return Authorization Number (RAN), which is available by calling the Kaivac, Inc. Customer Service Department. No returns will be accepted without a RAN.

This warranty does not apply to return freight costs, damage or defect caused by accident, negligence, misuse, fire or repair done by anyone other than a Kaivac authorized repair center. In no event shall Kaivac, Inc. be liable for incidental or consequential damages, or any damages to persons or property.

Please Note: Under no circumstances will the seller be liable for any loss, damage, expenses or consequential damages arising in connection with the use or inability to use seller's product. Kaivac, Inc. reserves the right to make changes or improvements to its equipment without notice. Some states do not allow the exclusion or limitation of incidental or consequential damages. This warranty is in lieu of any other warranty expressed or implied, including any warranty of merchantability or fitness for a particular purpose.

2.1 TOOL ARRANGEMENT

1200 Tool Arrangement

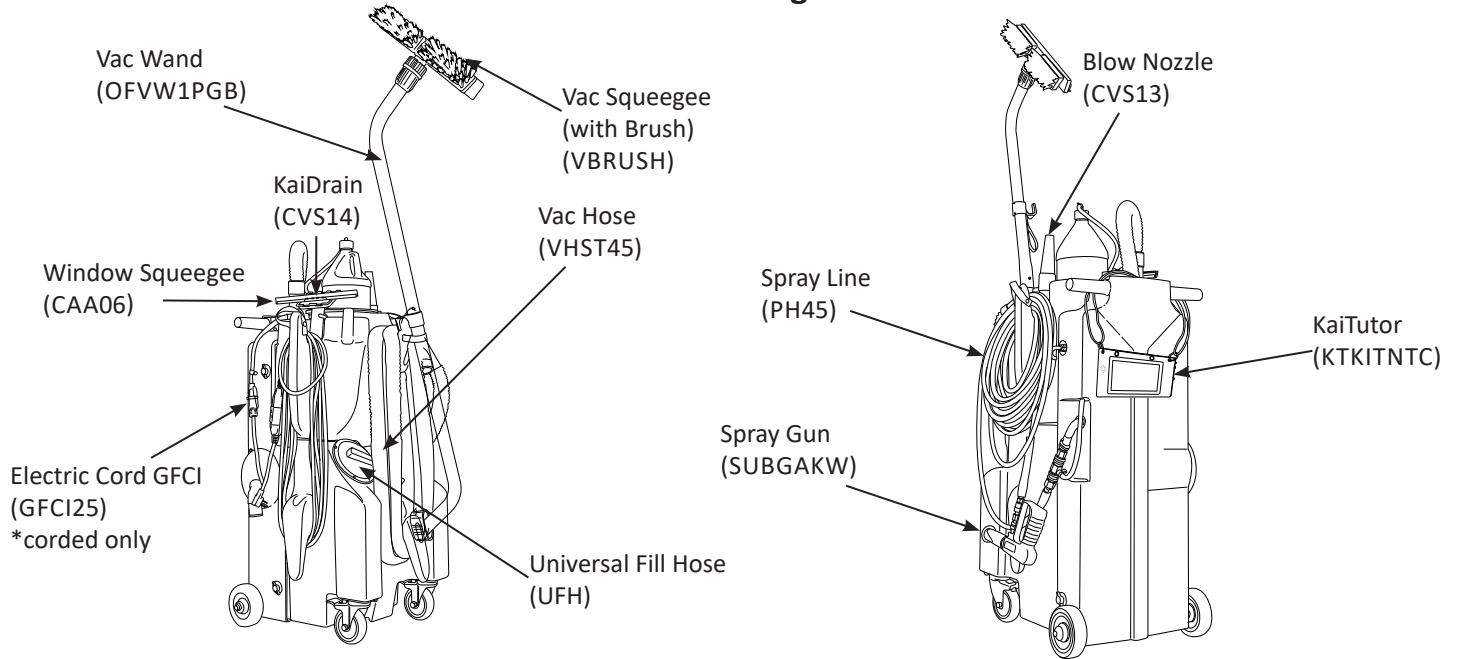

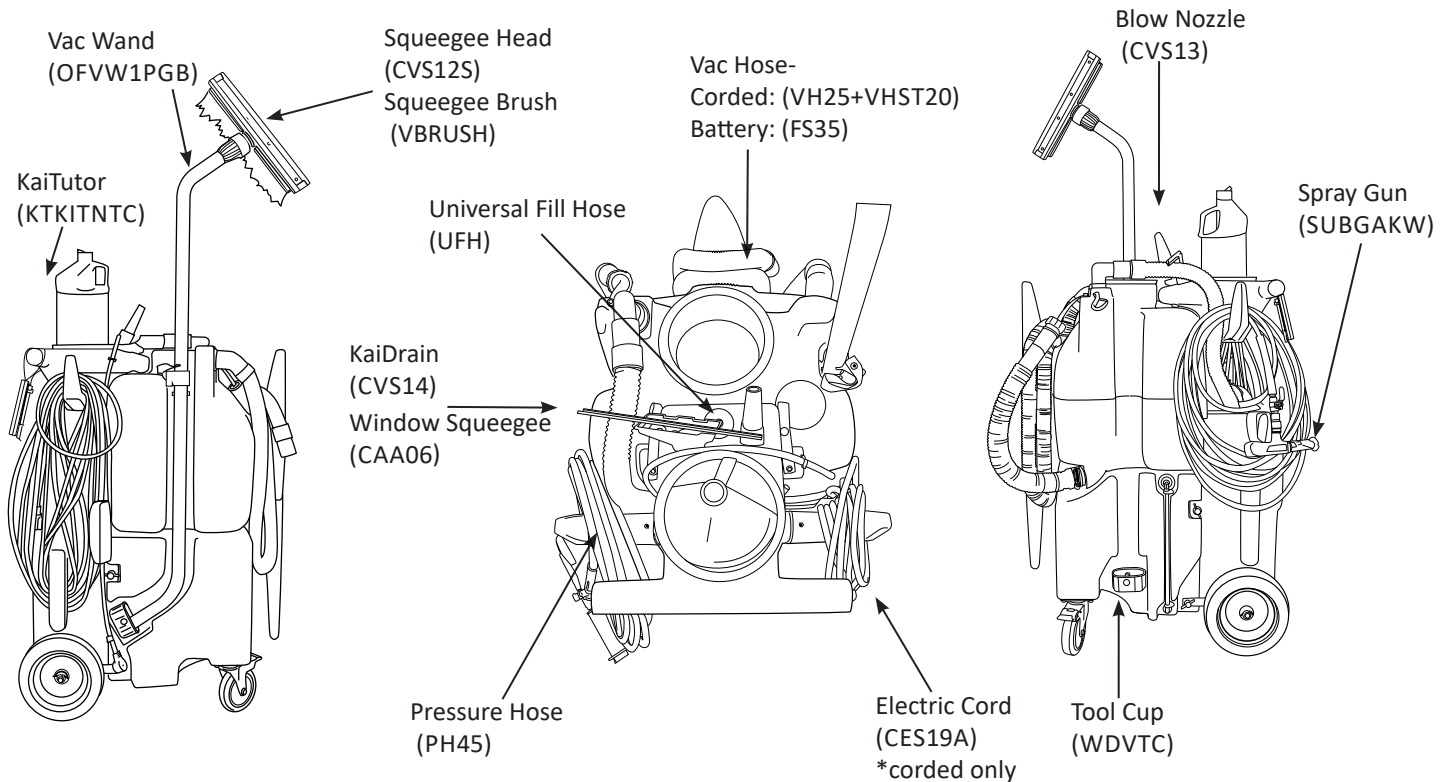

1700 and 2700 Tool Arrangement

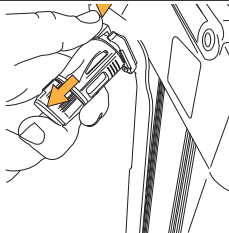
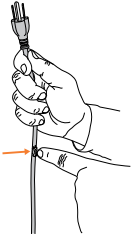
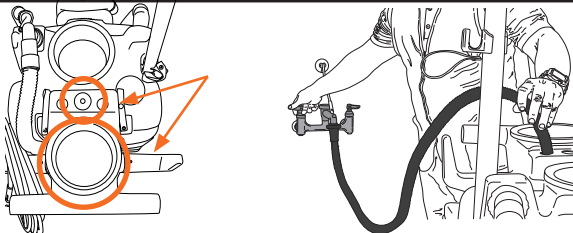
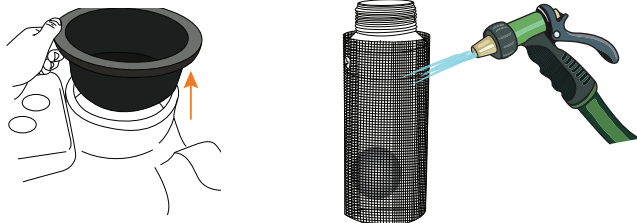
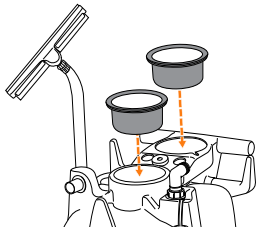
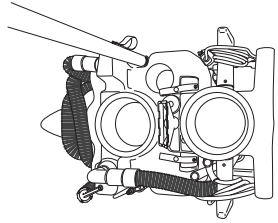

2.2 PREPARATION FOR USE

<p>1. Unplug the charger from the battery if applicable.</p> <p>CAUTION Avoid getting water on the machine.</p>	
<p>2. Check all hoses and spray lines for damage prior to use. If damage is found, do not continue until proper repairs are completed.</p>	
<p>3. Remove the water tank lid, or locate the Universal Fill Hose. Fill machine with clean, cool water.</p> <p>CAUTION Do NOT add chemical through these locations of the machine.</p>	
<p>4. Clean and spray the Float Cage located inside the Vacuum Tank. Ensure Float Cage is in place.</p> <p>CAUTION Do not use if Float Cage is not in place.</p>	
<p>5. Make sure Vac Lid Jug Holders are firmly on Vacuum Tank.</p>	
<p>6. Check machine for all tools and supplies needed to complete task. See <i>Tool Arrangement</i> in Section 2.2 of this manual.</p>	

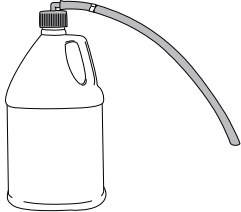
2.2 PREPARATION FOR USE (CONTINUED)

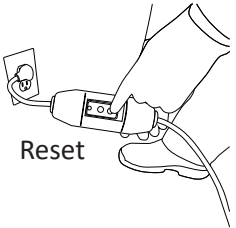
<p>7. Prepare the cleaning solution you will be using by attaching the chemical feed line and cap to the top of your chemical bottle. Then select the proper metering tip. (See placard for metering tip information)</p>	
<p>8. If using a cleaning product that foams, use a foam inhibitor to cut excess. Pour 2 capfuls of inhibitor in the Vac Hose with Vac running to coat inside of Hose.</p>	
<p>9. Plug in machine and test GFCI (Ground Fault Circuit Interrupter) if corded, to ensure it is working properly. You are now ready.</p>	

2.2 PREPERATION FOR USE (CONTINUED)

⚠ CAUTION

For the safety of self and others, do not point the spray gun at others or self. Spray only the intended object.

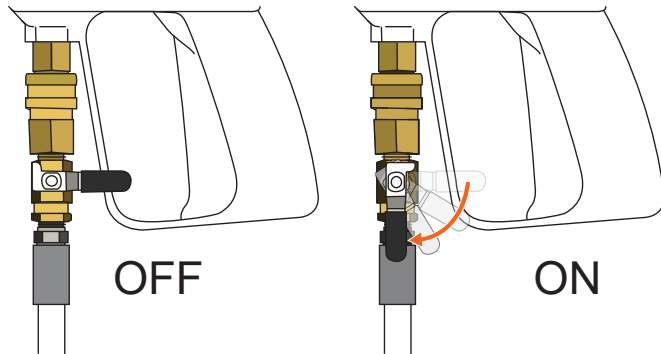

To turn Spray Gun off or on, switch the valve connected to Spray Gun as shown. The Spray Gun is connected to the Spray Line.

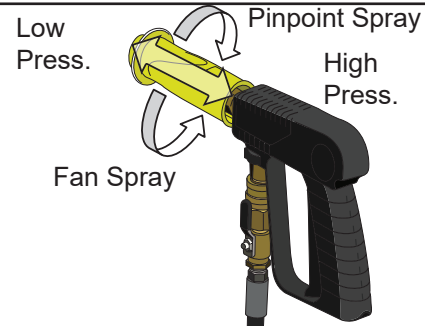

Chemicals applied in *Low Pressure* setting only. Chemicals must be cleared from the Spray Line **prior to High Pressure** rinsing. To do this turn OFF the Chemical Valve, then spray in the *Low Pressure* setting for 15 seconds.

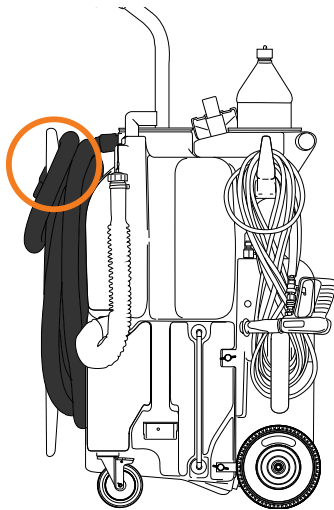

The Vac Hose is located on side of machine as shown.

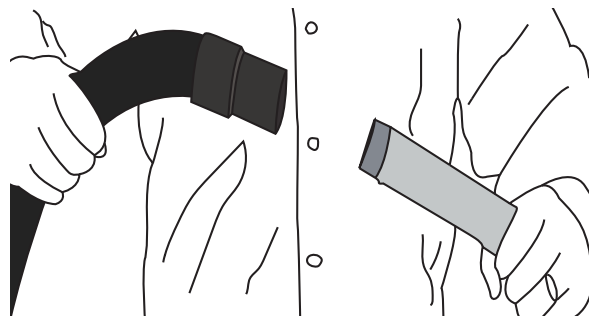

Attach Vac Wand to Vac Hose as shown above.

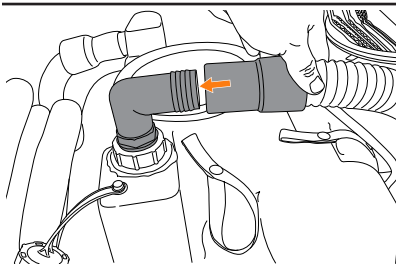
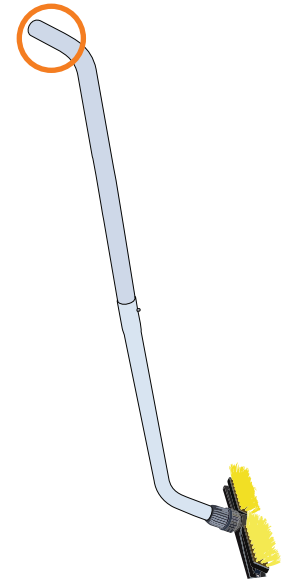

Ensure elbow hose is connected at top of machine.

⚠ CAUTION

DO NOT DISCONNECT AND DO NOT USE AS VACCUM

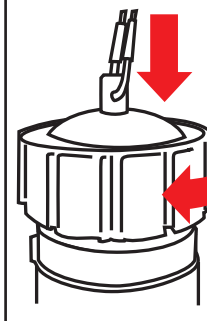

Ensure dump hose is secured to cap-and-tether. Check this daily.

Dump excess from the vaccum tank by unscrewing the cap.

2.3 FILLING THE UNIT

For No Touch Cleaning machines, there are two designated filling areas. The first area is accessed by running water through the Universal Fill Hose. The next is found by lifting the Vac Lid Jug holder at the top of the machine that is connected to the Water Tank, and removing it to reveal the inside. The unit can be filled by this location as well.

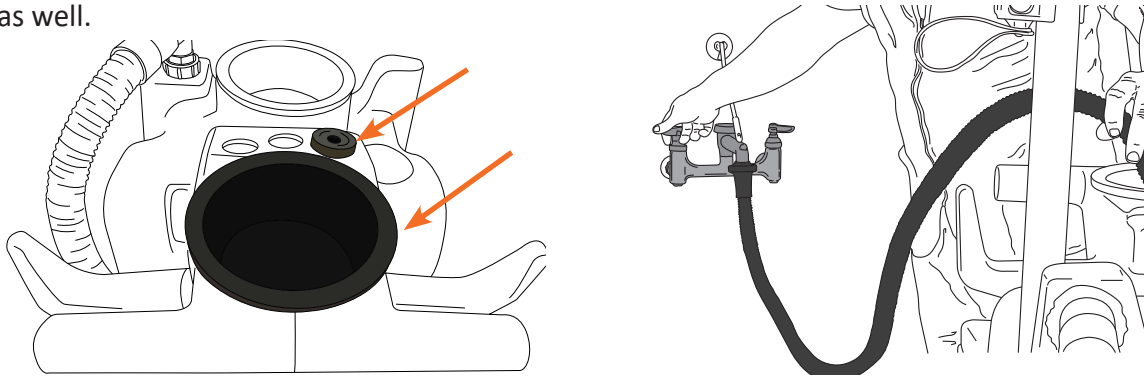

Note the location of the Sight Gauge on the side of the Water Tank. Use the Sight Gauge feature to see how much water is in the machine. If water is low, ensure you refill the tank by using the fill port. The Sight Gauge will help see the water level, do not overfill or overflow from the tank will occur.

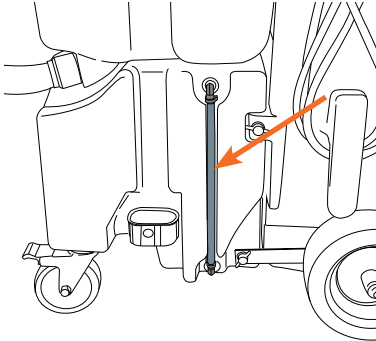

Fill the tank with Kaivac or Kaivac approved Chemicals. Follow the proper dilution instructions on bottles or dispenser. For accuracy and convenience, use Kaivac proportioned chemical packets.

TIP: IF A CHEMICAL IS BEING USED, USE ONLY THE RECOMMENDED DILUTION.

2.4 EMPTYING VACUUM TANK

If the Vacuum Motor shuts off before the job is complete, the Vacuum Tank may be full and need to be emptied. Lift the Vacuum Motor to check liquid level inside the Vacuum Tank. If unit is full or your job is complete, follow the instructions below to empty Tank into appropriate sink/drain.

Once cap is removed, lower Dump Hose into appropriate sink/drain. To prevent an accidental spill or overflow from the Dump Hose, be careful to keep hose end upright until it is over sink/drain.

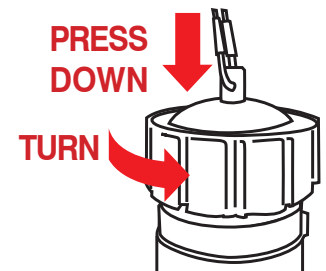
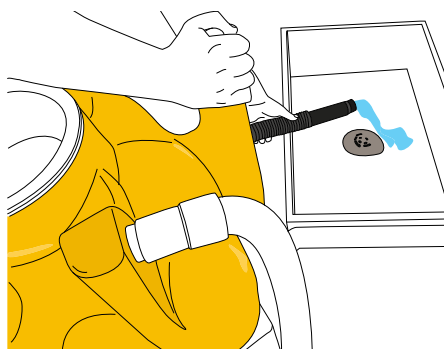

To begin the dumping process, you must first press down on the Cap and turn counter-clockwise

2.5 BATTERY USE

The bracket mounted on the black box is where the Power Pack is mounted.

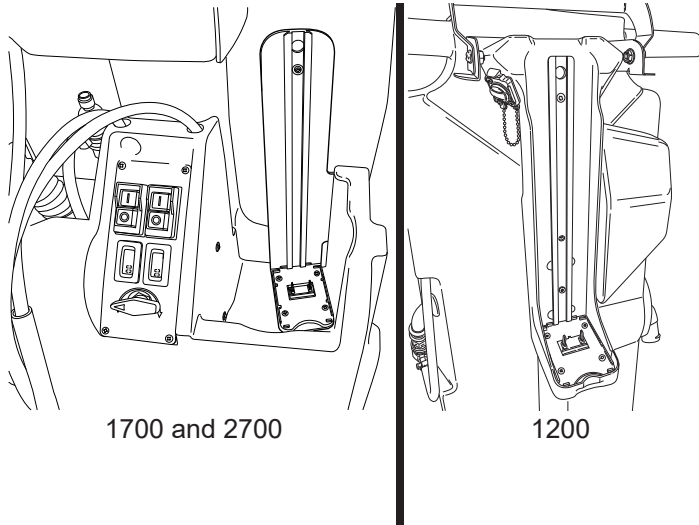

Lower Power Pack onto bracket slide, lowering it down into place.

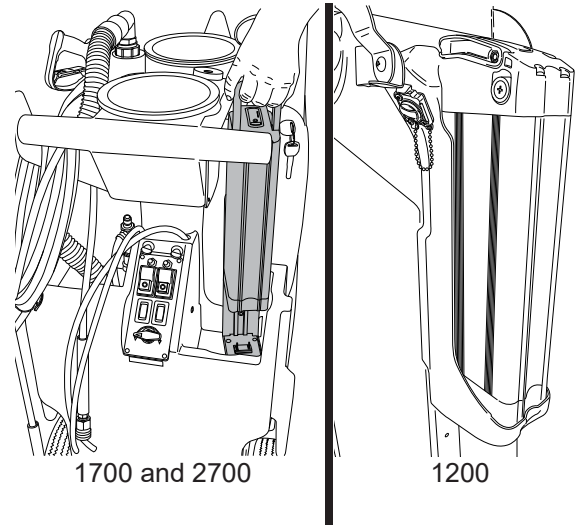

The Charging Port location for the Power Pack is pictured below.

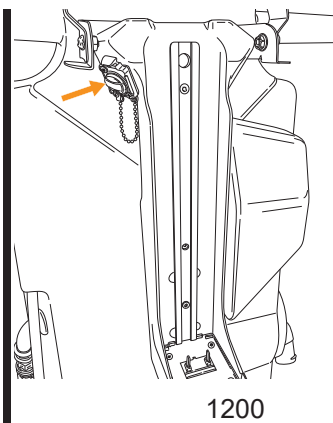
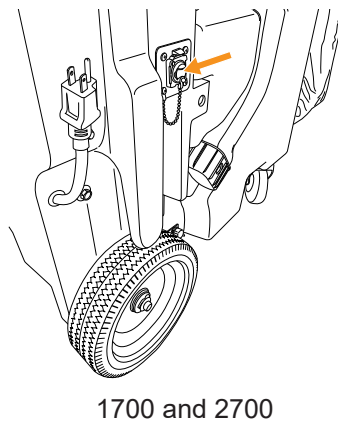

Insert Charger into Charge Port (push until it clicks) as displayed below.

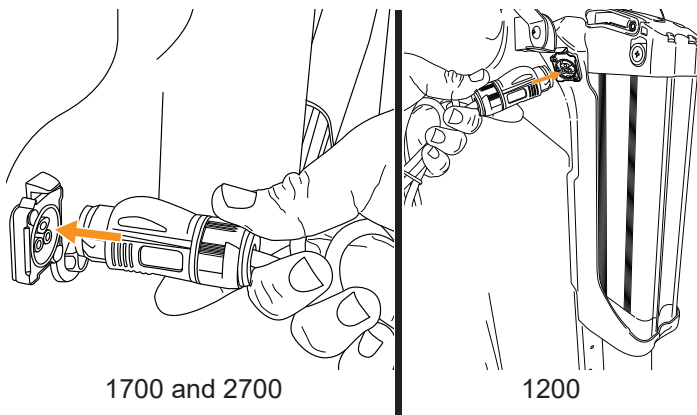

To unplug charger, press button and pull back on metal plug. Do not pull cord.

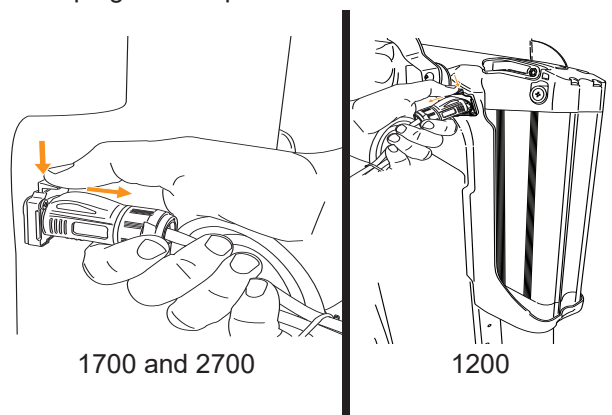

3.1 MACHINE MAINTENANCE

CAUTION Always unplug machine before accessing electrical component.

ITEM	PROCEDURE
Floor Squeegee	<ul style="list-style-type: none"> • Check condition of squeegee blades and wheels on the floor tool. • Rough floor surfaces will cause the blades and wheels to wear out more quickly. Replace as necessary.
Spray Gun	<ul style="list-style-type: none"> • Check spray pattern. If spray pattern will not pinpoint, clean orifice by removing it with an Allen wrench and flushing. Replace if needed. • If nozzle becomes difficult to move from high to low pressure, lubricate nozzle with lithium grease.
Pressure Hose	<ul style="list-style-type: none"> • Wipe clean after each use. • Check for cuts or frays in the hose jacket, particularly at the end of the fittings. Replace hose if cuts are found.
Water Tank	<ul style="list-style-type: none"> • Check condition of filter in water tank. Clean as needed. • Empty the water tank to prevent mildew and bacteria growth. Empty tank by dipping the vacuum hose into the water tank and transferring the water to the vacuum tank.
Vacuum Tank	<ul style="list-style-type: none"> • Empty and flush vacuum tank. • Clean and disinfect. • Check the float shutoff screen to be sure it is not blocked or dirty. A plugged filter screen restricts airflow and results in reduced suction.
Leaks	<ul style="list-style-type: none"> • Be alert for leaks around hoses, fittings, spray wand, tanks or elsewhere. • Discontinue use until leaks are repaired.
Electrical System	<ul style="list-style-type: none"> • The ground fault circuit interrupter (GFCI) must be tested before each use. • Electrical cord must be inspected for tears or cuts in the insulation.
Vacuum Wand	<ul style="list-style-type: none"> • Use a wire or coarse brush with acid cleaner to remove residue from threads on the coupling and coupling nut. Apply grease when done.
HEPA Filter	<ul style="list-style-type: none"> • Replace every 3-6 months depending on use.
Float Cage	<ul style="list-style-type: none"> • Ensure cage is sprayed and cleaned daily to remove debris.

3.2 VACUUM DIAGRAM

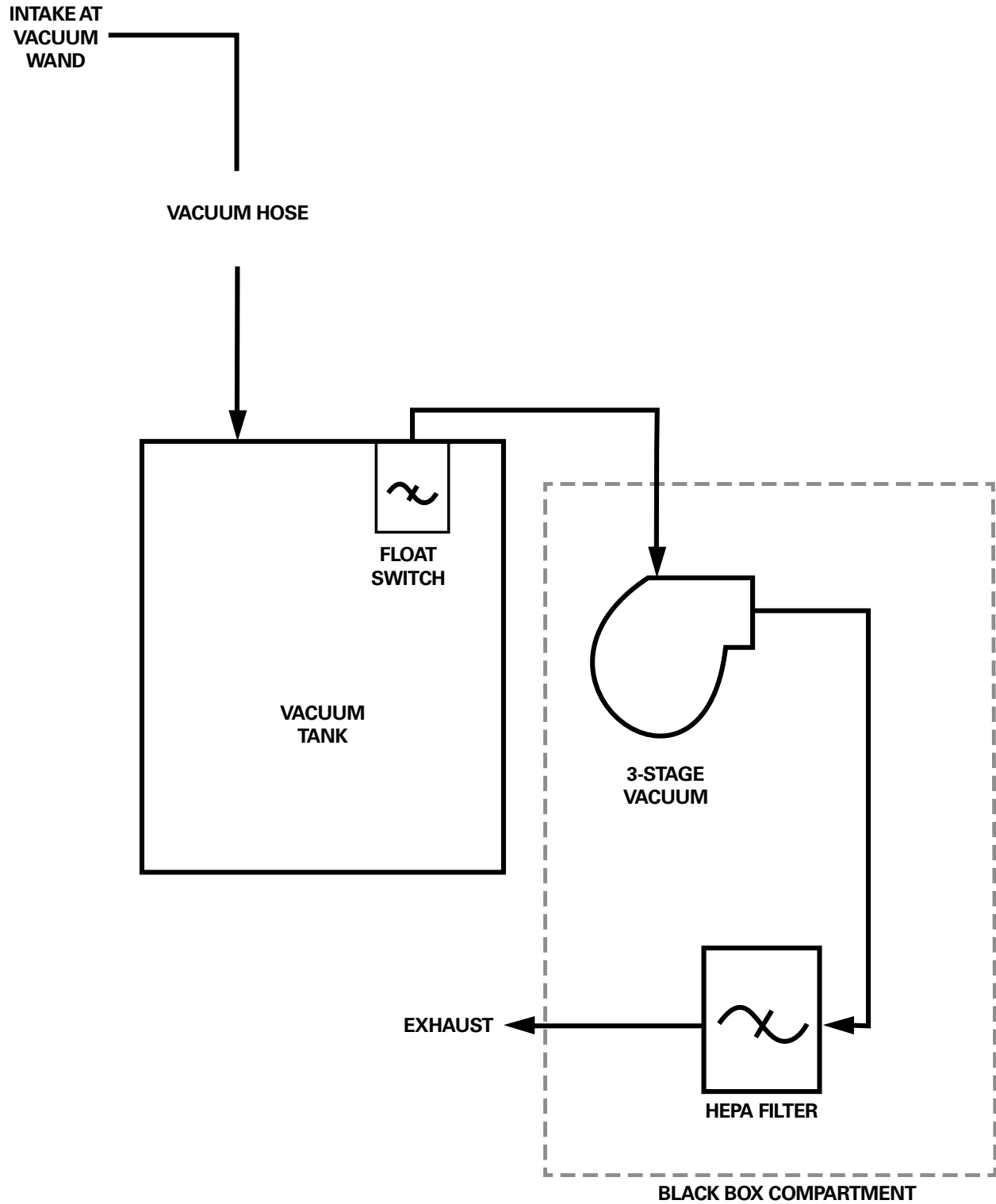

3.3 PUMP DIAGRAM

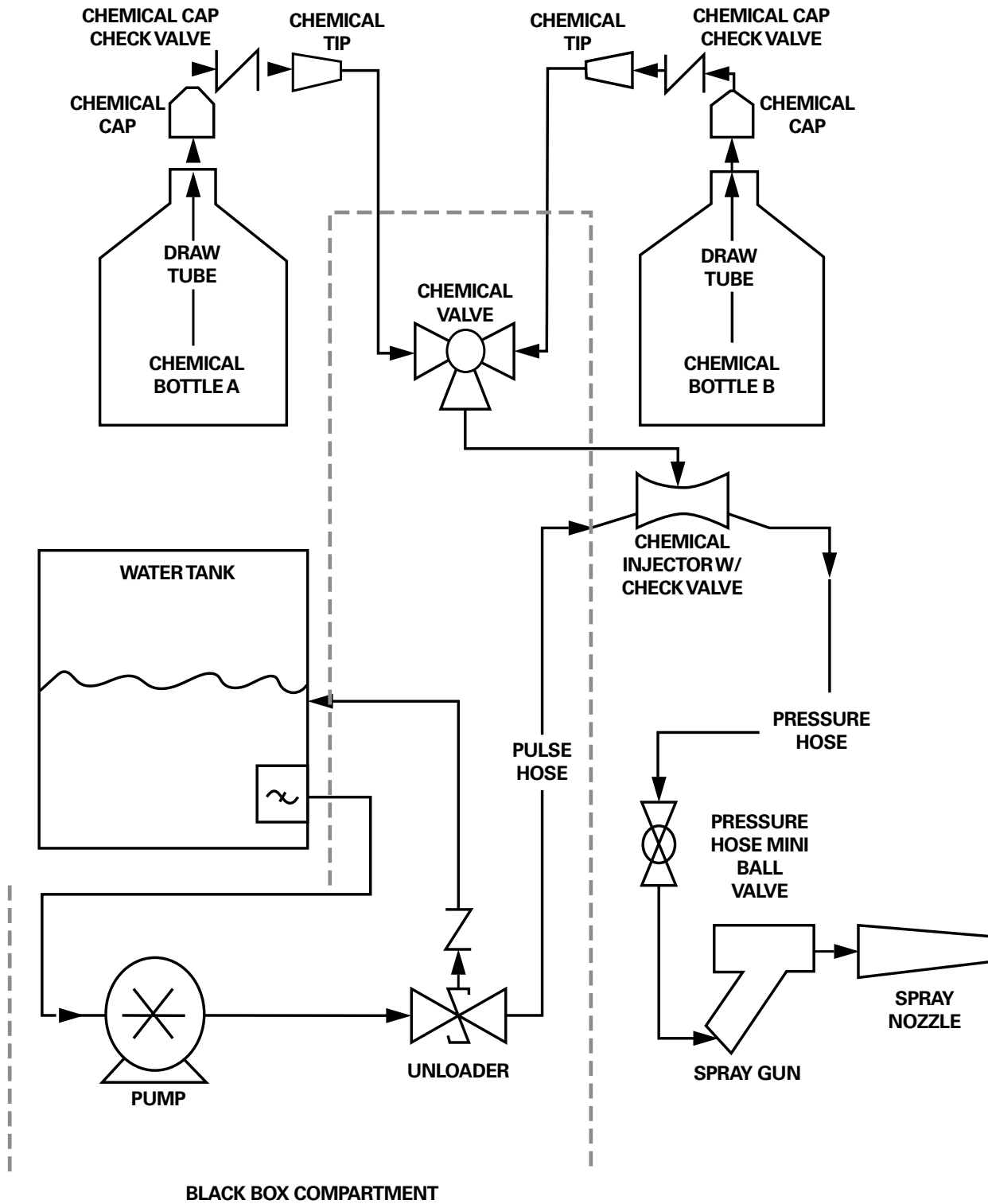

3.4 1200 AC/CORDED ELECTRICAL DIAGRAM

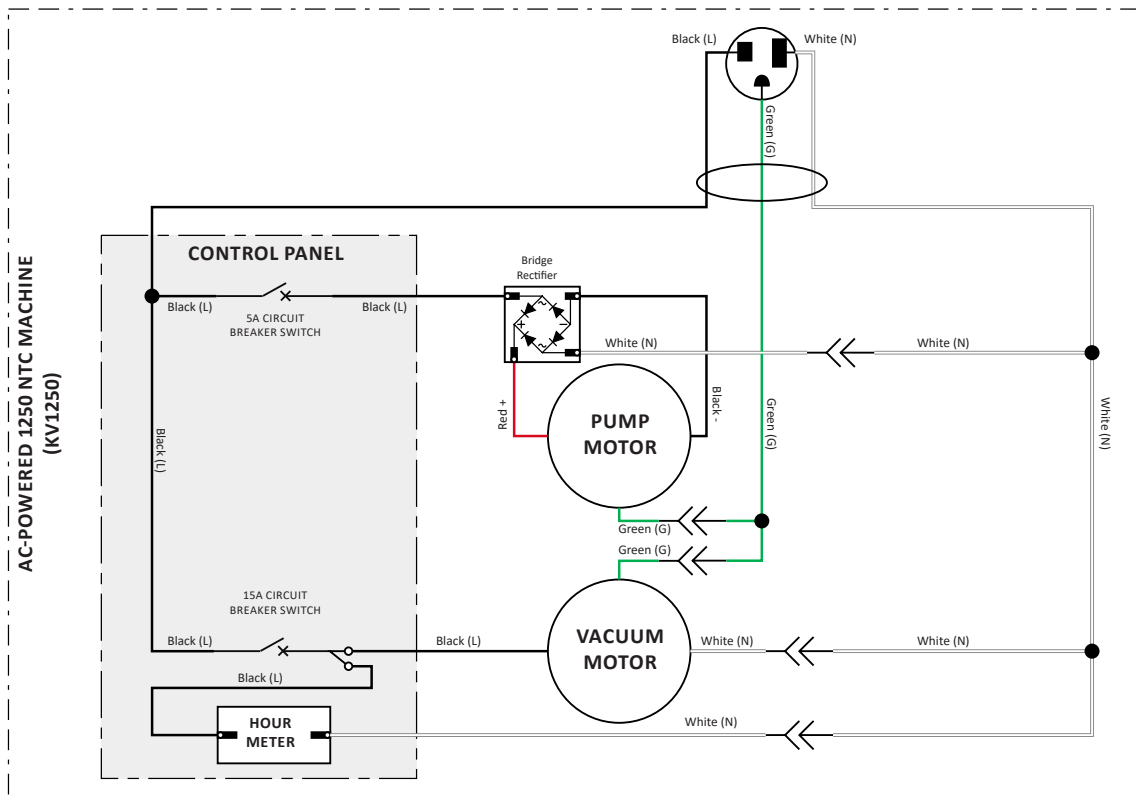

3.5 17/2700 AC/CORDED ELECTRICAL DIAGRAMS

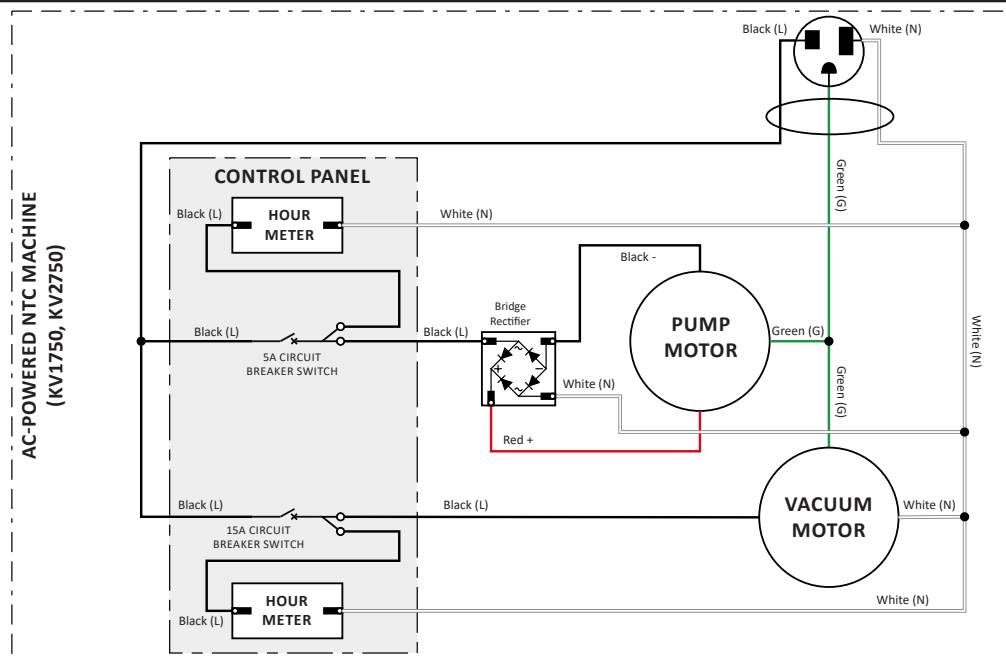

3.6 1200 QUICK CHANGE ELECTRICAL DIAGRAM

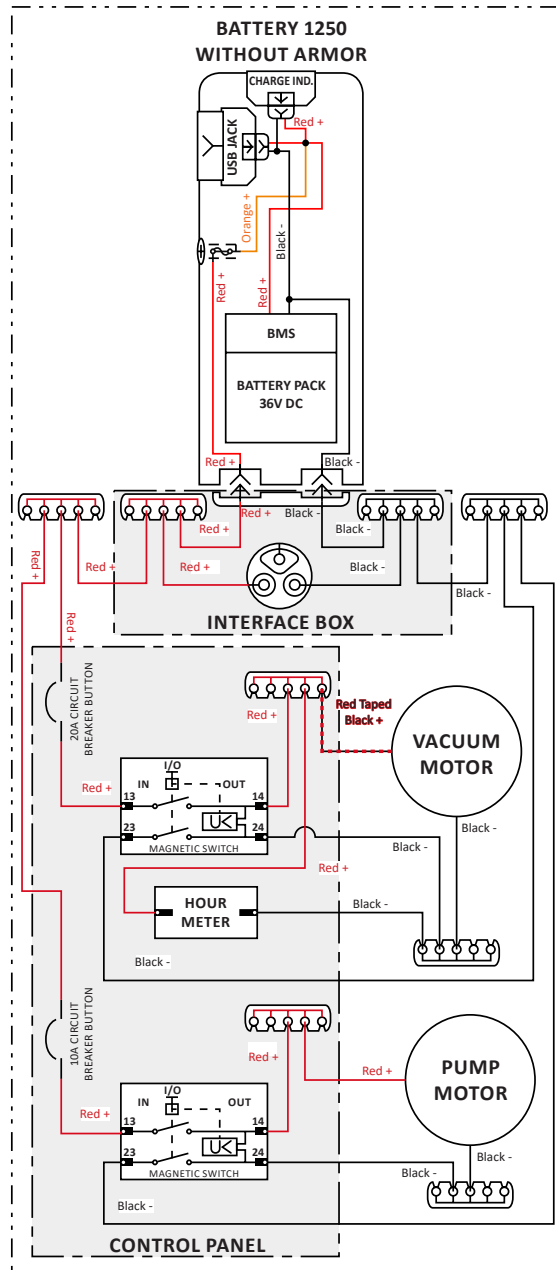

3.7 17/2700 QC POWER PACK ELECTRICAL DIAGRAM

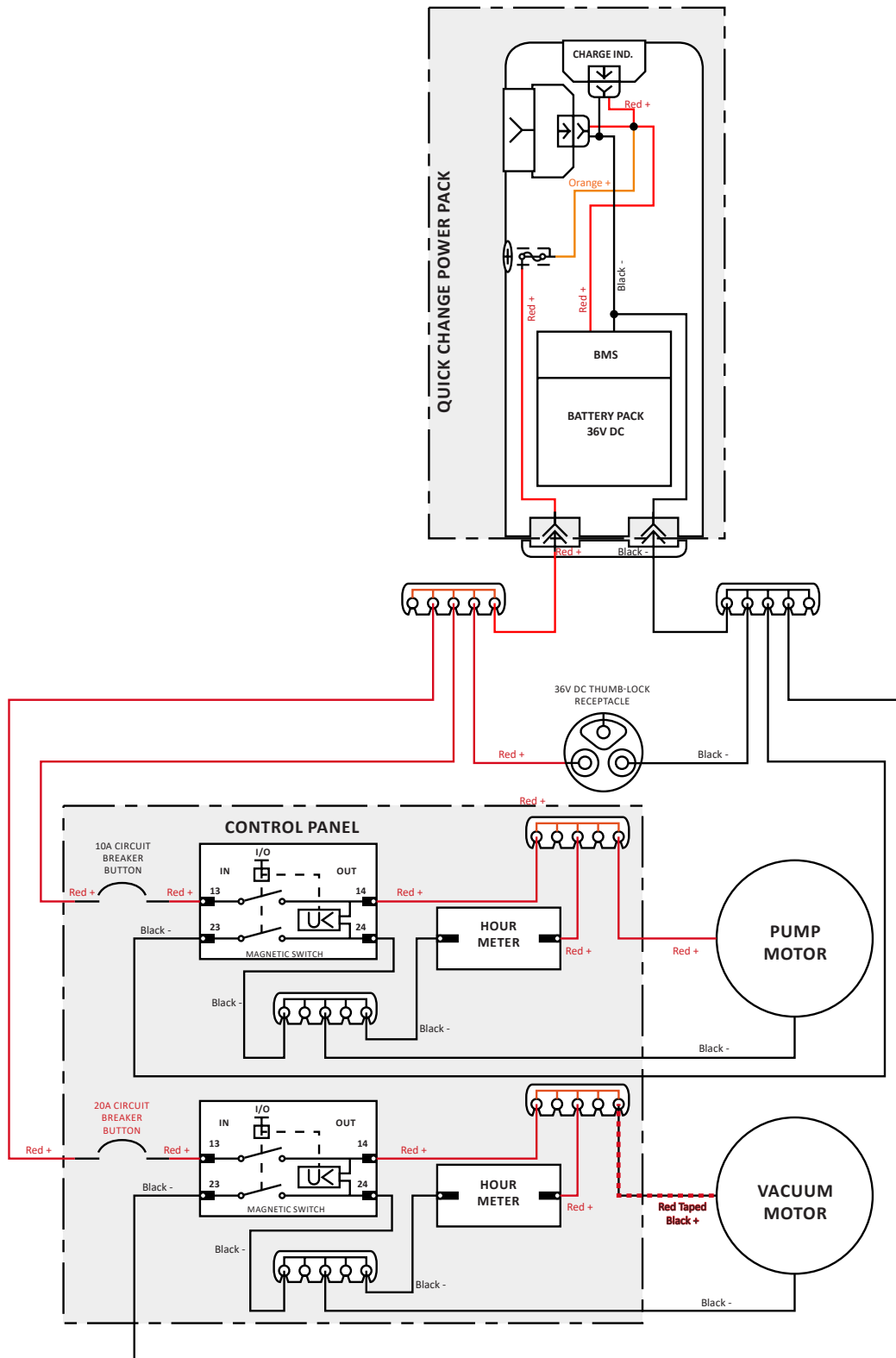

4.1 TROUBLESHOOTING



CAUTION Always unplug machine before accessing electrical component

AREA	PROBLEM	POSSIBLE CAUSE	SOLUTION
CAUTION Electrical	No Power to pump or vac motor	Machine not plugged in	Plug machine in
		Switch not "on"	Check switches for "on"
		GFCI tripped	Test and reset GFCI
		Building circuit overloaded	Check and reset circuit
		Switch wires loose	Disconnect power and check for loose wire
		Connections loose	Disconnect power and check for loose wire under panel
	Electrical burning smell WARNING TURN MACHINE OFF IMMEDIATELY.	Vac motor brushes worn	Remove vac motor and repair
		Vac motor hung up	Release pressure on hose and jog vac switch, or replace
		Pump motor hung up	Release pressure on hose and jog pump switch, or replace
Vacuum System	No/Weak vacuum	Vac tank full	Empty vac tank
		Squeegee blades or wheels worn	Replace wheels or blades and check periodically
		Float shutoff screen dirty	Spray off float screen to clean
		Float ball stuck	Tap float and release/clean
		Damaged hose	Cut and repair/replace
		Dump hose plug missing	Contact dealer and replace
		Access lid not right	Tighten lid hand tight
		Vacuum hose plugged	Flush hose to remove debris
		Too much liquid in vac hose	Allow air in when vacuuming
		Vac hose still wrapped	Unwrap vac hose fully
		Exhaust plugged	Clean exhaust port and HEPA filter
		Leak in vac tank	If repairable, clean and dry affected area and seal with silicone
	HEPA filter clogged	Remove HEPA filter and clean	
	Moisture from exhaust	Vac tank full	Dump vac tank
		Float shutoff missing	Replace
Excessive foam in vac tank		Use defoamer	
Blow Dry System	No air flow	Hose disconnected	Reconnect hose
	Moisture from exhaust	Water in blow hose	Dry blow line
	Suction, not blow action	Vacuum hose connected to vac tank	Reconnect to vac motor exhaust hose

4.2 TROUBLESHOOTING



Always unplug machine before accessing electrical component.

AREA	PROBLEM	POSSIBLE CAUSE	SOLUTION
High Pressure System	No water from pump or low pressure	Out of water	Fill water tank
		Gun nozzle plugged	Remove orifice with Allen wrench and clean
		Air in pump (vapor lock)	Use power prime technique
		Gun orifice missing	Replace orifice
		Water tank filter plugged	Clean tank and filter
		In-line bowl filter plugged	Remove filter cover and clean
		Bowl filter lid loose	Gently tighten bowl cover
		Pressure hose damaged	Repair or replace
		Quick disconnect leaking	Tighten or replace
		Injector plugged	Remove safety cap from chemical and blow small amounts of compressed air into line
		Pulse hose damaged	Repair or replace
		Regulator failed	Replace
		Hose kinked	Unkink and check for damage
	Seals in pump need replaced	Remove and replace seals	
	Bad fan pattern or pinpoint pattern on gun	Debris in nozzle	Remove orifice with Allen wrench and clean
Orifice damaged		Remove and replace	
Chemical Injection System	No chemical flow	Out of chemical	Refill chemical
		Safety cap not secure	Check safety cap/tighten
		Chemical valve "off"	Check on/off valve
		Safety cap plugged	Replace cap
		Spray gun in wrong mode	Make sure gun nozzle is pulled out away from gun chemical mode
		Metering tip plugged	Check metering tip for clog
		Injector plugged	Remove safety cap from chemical and blow small amounts of compressed air into line
		Air entering system	Check for air entering system around chemical lines or injector
		Injector installed backwards	If fluttering or pulsing sound can be heard while spraying or when machine is running, it is possible that your injector is in backwards. Remove; reinstall.
		Kink in chemical line	Replace chemical line

4.3 TROUBLESHOOTING



Always unplug machine before accessing electrical component.

AREA	PROBLEM	POSSIBLE CAUSE	SOLUTION
Chemical Injection System continued	Not enough chemical	Metering tip plugged	Remove and clean
		Wrong metering tip	Check and replace per chart
	Chemical line blows off safety cap	Debris in injector	Remove safety cap from chemical and blow small amounts of compressed air into line
		Water back flows into chemical bottle	Bad seat on injector check valve
		Bad safety cap	Replace safety cap
Dump System	Dump hose will not empty tank	Dump hose cap not removed	Remove cap
		Clog in bottom of tank	Tip dump contents, remove debris
	Dump hose leaks	Hose cut	If leak is less than 4" from tank side, cut and reattach, or replace
		Clamp loose	Tighten hose clamp
		Dump cap missing	Replace cap
Wheels and Casters	Wheels will not roll; rubbing	Flat tires	Inflate tires to 30 p.s.i.
		Debris wrapped around axle	Check for debris on axle
		Bearings tight	Grease bearings
		Wheels too loose on axle	Remove wheel, add washers to take up slack
		Bearings falling out	Replace bearing assembly
Squeegee Head	Floor streaks	Worn blades or wheels	Replace wheels and/or blades
	Squeegee head does not easily rotate when installed on wand	Brass ring on wand not in groove	Loosen coupling nut and re-position head on groove
		Coupling nut too tight	Loosen 1/2 turn
	Head will not stay on wand	Coupling nut cracked	Replace
		Brass ring worn	Replace
	Premature blade wear	Squeegee wheels worn	Check wheels for wear/replace
Sucks to the floor too tightly	Squeegee wheels worn	Check wheels for wear/replace	

4.4 TROUBLESHOOTING TIPS

• POOR VACUUM PICKUP

1. Check Squeegee Blades. If blades are worn or damaged, replace Squeegee Head.
2. Clean float cage.
3. Check for leaks in the Vacuum Hose or Gasket.
4. Check for clogged Vacuum Hose.
5. Check to see if float ball was tripped.

• VACUUM SHUTS OFF PREMATURELY

1. Check Float Cage; clean if dirty.
2. Cleaning Chemicals may be producing too much foam. Use correct Chemicals.

• OTHER ISSUES? CONTACT TECHNICAL SUPPORT

PHONE:

United States and Canada: 1-800-287-1136

International: 1-513-887-4600

EMAIL:

info@kaivac.com

For Technical Support Contact Form go to: <https://www.kaivac.com/contactus.php> and choose Technical Support tab.

4.5 REPLACEMENT (MONTHLY)

The following tasks should be performed monthly to keep your system operating at peak performance.

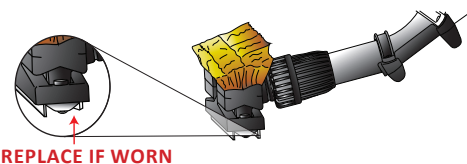

Check for worn squeegee blades. Worn blades cause streaking and loss of vacuum suction.

Unscrew cuff at end of Vac Wand, remove old head and replace with new every 6-8 weeks for optimal performance.

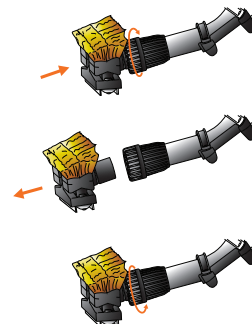

IMPORTANT: If cuff is removed, ensure Brass Ring stays in place.



5.1 1200 VAC TANK ASSEMBLY

[WAXIE P/N: VTA12WX] [ENVOY P/N: VT1200]

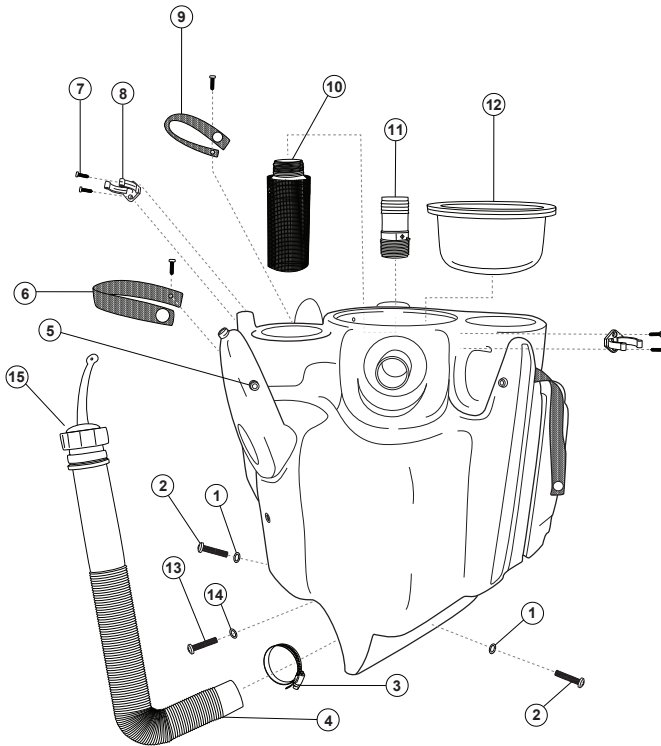

#	PART NO.	PART DESCRIPTION
1	KMB16	3/8 SST FLAT WASHER
2	CSS91	3/8 X 2 1/4 BOLT
3	CSS03	1 9/16 - 2 1/2 HOSE CLAMP
4	DH25	26" X 1.5" DUMP HOSE 2" CUFF
5	CSS20	SNAP STUD
6	SUBSS7	7 IN. SNAP AND STRAP
7	CSS17	#8 FLAT HEAD SQUARE SCREW
8	CSS14	13 CLAMP, FOR TOOLS
9	SUBSS9	9 IN. SNAP AND STRAP
10	KZFLOAT	FLOAT SHUT OFF
11	CSS173	1 1/4 NPT X 1 1/2 HOSE ADAPTER
12	VLJHA	VAC LID, JUG HOLDER ASSEMBLY
13	CSS58	3/8 X 16 X 1 SST SCREW
14	CSS48	3/8 SST LARGE OD WASHER
15	SCCAP	DUMP HOSE CAP

5.2 1200 WATER TANK ASSEMBLY

[P/N: WTA12BKW]

#	PART NO.	PART DESCRIPTION
1	WDVTC	OMNIFLEX VAC TANK TOOL CUP
2	CSS398	8 X 3/4 SS TRUSS SCREW
3	LID4	LID WITH TETHER 4 1/4 IN
4	MFILT	MUSHROOM FILTER
5	CSS142	3/8 IN BRASS HOSE BARB
6	CPS20	3/8 NPT X 1/2 BRASS HOSE BARB
7	LCST4	4 TOTAL LOCK CASTER
8	CSS133	5/16 SPLIT LOCK WASHER 300 SS
9	CSS132	5/16-18X1 BUTTON HEAD

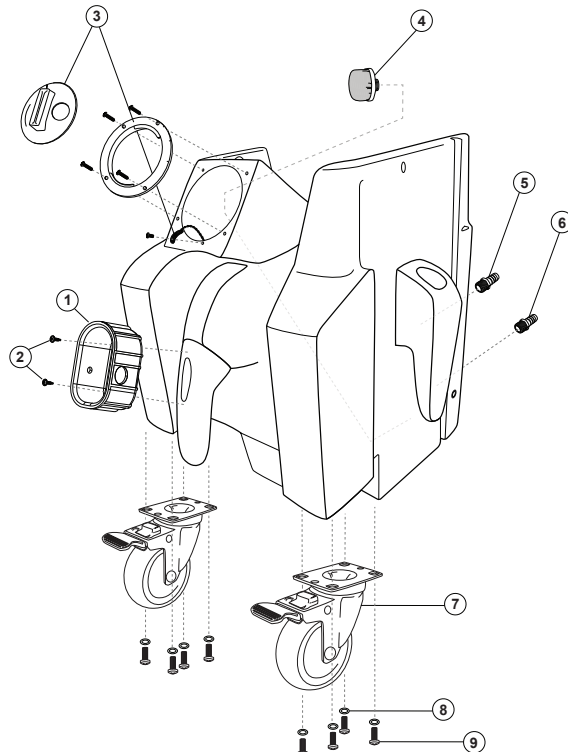

5.3 1250 BLACK BOX ASSEMBLY

[P/N: BBA1250S]

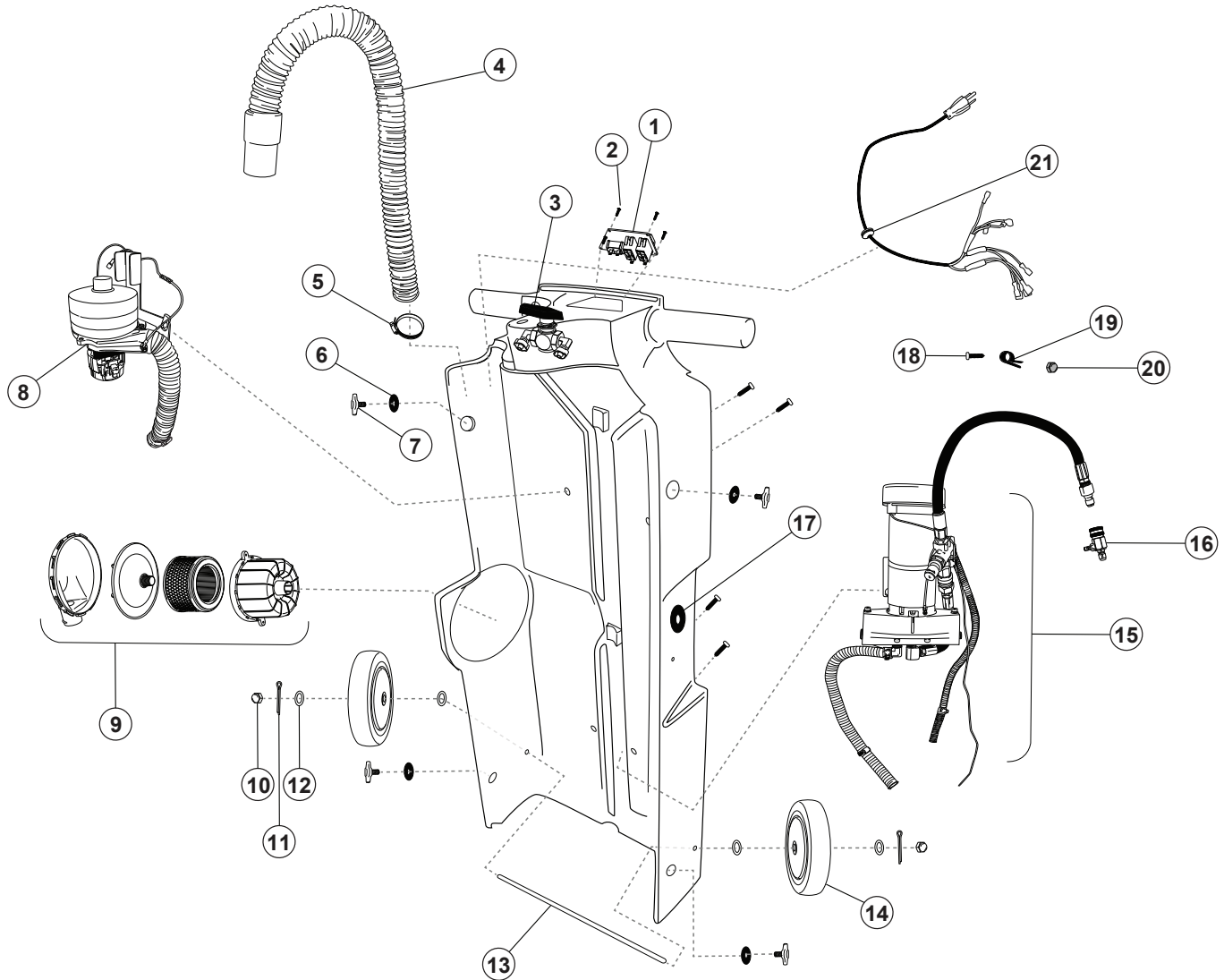

#	PART NO.	PART DESCRIPTION
1	SPA1250	SWITCH PANEL ASSEMBLY FOR KV1250
2	CSS17A	8 SST SCREW 3/4
3	VA2WS	VALVE ASSEMBLY 2 WAY FOR KV1250 SST
4	VMH27	VAC MOTOR HOSE NEW
5	CSS03	1 9/16 - 2 1/2 HOSE CLAMP
6*	CSS48	3/8 SST LARGE OD WASHER
7*	CSS156	3/8 X 3/4 T THUMB SCREW YELLOW
8	VMA1200	VAC MOTOR ASY KV1200
9	HEPAHA2	HEPA HOUSING ASSEMBLY
10	CSS01	1/2 IN PUSH CAP NUT

11	CSS72	COTTER PIN 1/8 DIA X 11/4 LG
12	CSS40	1/2 DIA WASHERS
13	AX195	AXLE 19.75 X 1/2 CR STEEL
14	WHL5	5 X 1 1/2 TPU WHEEL W-1/2 BB
15	PA1250	PUMP ASSEMBLY FOR KV1200
16	CPS12JQCS	QUICK CONNECT INJECTOR (SST)
17	CSS175	3/4 ID X 1 3/8 OD GROMMET
18	CSS174	1/4-20 X 5/8 MACHINE SCREW SS
19	CSS130	RUBBER CUSHIONED STEEL LOOP
20	CSS101	ACORN NUT 1/4 20
21	PCKV1A	POWER CORD MOLDED WITH GROMMET

* Shown but not part of assembly

5.4 1250 QC BLACK BOX ASSEMBLY

[P/N: BBA1250QCS]

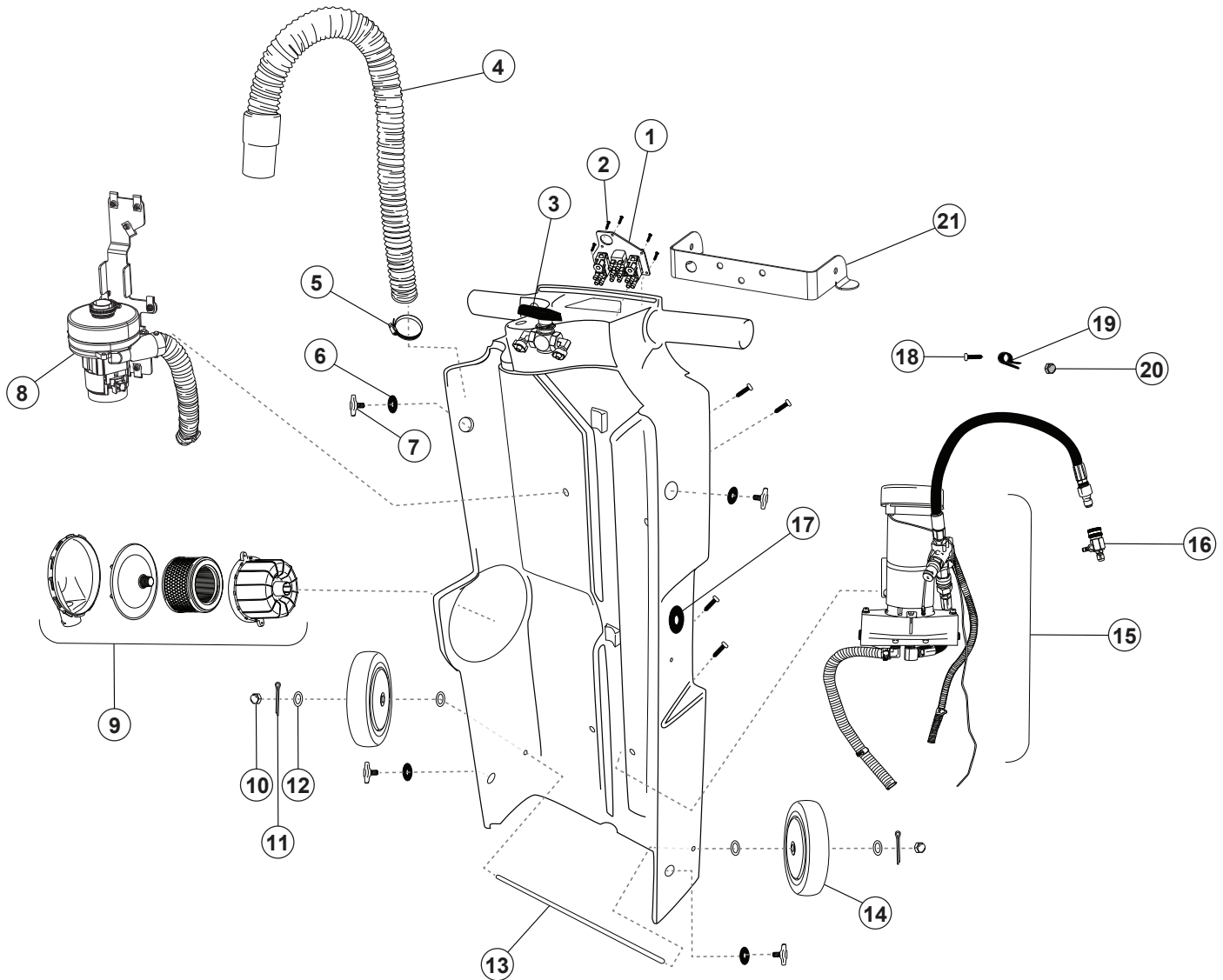

#	PART NO.	PART DESCRIPTION
1	SPA1250B	SWITCH PANEL ASSM FOR KV1250QCBATT
2	CSS17A	8 SST SCREW 3/4
3	VA2WS	VALVE ASSEMBLY 2 WAY FOR KV1250 SST
4	VMH27	VAC MOTOR HOSE NEW
5	CSS03	1 9/16 - 2 1/2 HOSE CLAMP
6*	CSS48	3/8 SST LARGE OD WASHER
7*	CSS156	3/8 X 3/4 T THUMB SCREW YELLOW
8	VMA1200B	VAC MOTOR ASY KV1200 36V
9	HEPAHA2	HEPA HOUSING ASSEMBLY
10	CSS01	1/2 IN PUSH CAP NUT

11	CSS72	COTTER PIN 1/8 DIA X 11/4 LG
12	CSS40	1/2 DIA WASHERS
13	AX195	AXLE 19.75 X 1/2 CR STEEL
14	WHL5	5 X 1 1/2 TPU WHEEL W-1/2 BB
15	PA1250B	PUMP ASSEMBLY FOR KV1200
16	CPS12JQCS	QUICK CONNECT INJECTOR (SST)
17	CSS175	3/4 ID X 1 3/8 OD GROMMET
18	CSS174	1/4-20 X 5/8 MACHINE SCREW SS
19	CSS130	RUBBER CUSHIONED STEEL LOOP
20	CSS101	ACORN NUT 1/4 20
21	KTB12	KAITUTOR 1200 ADAPTER BRACKET

* Shown but not part of assembly

5.5 1200 SWITCH PANEL ASSEMBLY

[P/N: SPA1250]

#	PART NO.	PART DESCRIPTION
1	5ACBS (PUMP)	5 AMP CIRCUIT BREAKER SWITCH BLACK
2	15ACBS (VAC)	15 AMP CIRCUIT BREAKER SWITCH WHITE
3	CSS123	QUICK CONNECT PIGGY BACK TERM
4	JWB5	JUMPER WIRE BLACK 5 IN
5	HMETER	SNAP IN DIGITAL METER
6	SPLSSB1200	SWITCH PLATE SS W/ BREAKER
7*	CSS17A	8 SST SCREW 3/4

* Shown but not part of assembly

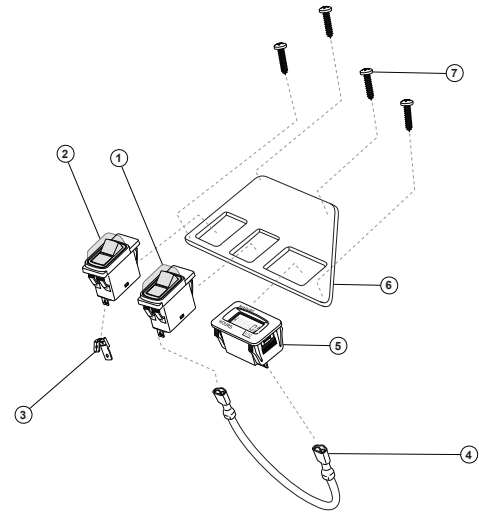

5.6 1200 QC SWITCH PANEL ASSEMBLY

[P/N: SPA1250B]

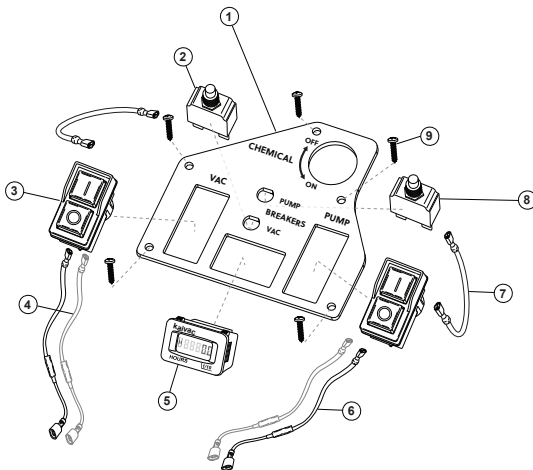

#	PART NO.	PART DESCRIPTION
1	SPLSSBB1200	SWITCH PLATE FOR KV1250QCBATT
2	20ACBB	20A CIRCUIT BREAKER BUTTON
3	18AEMS2	18A ELECTROMAGNETIC SWITCH HEAVY DUTY
4	JWR12	JUMPER WIRE RED 12GA 1/4F TO BARE 12IN
5	HMETER	SNAP IN DIGITAL METER
6	JWB12	JUMPER WIRE BLACK 12GA 1/4F TO BARE 12IN
7	JWR5	12 GA. JUMPER WIRE RED 5 IN
8	10ACBB	10A CIRCUIT BREAKER BUTTON
9*	CSS17A	8 SST SCREW 3/4

* Shown but not part of assembly

5.7 1200 VALVE ASSEMBLY

[P/N: VA2WS]

#	PART NO.	PART DESCRIPTION
1	SPH18	2 WAY VALVE HOSE FOR KV1250
2	CPS50B	BLACK KNOB FOR 3 WAY VALVE
3	CPS50C	SET SCREW FOR 3 WAY VALVE
4	SPH28	ELECT BOX CHEMICAL HOSE 28 IN
5	CPS68S	STEEL 90 DEG 1/8 NPT MALE X
6	CPS65	1/2 IN CLAMP
7	CPS43S	2 WAY STEEL VALVE VITON SEALS (INCLUDES KNOB)
8	CSS21F	SNAP GRID HOSE CLAMP SIZE C

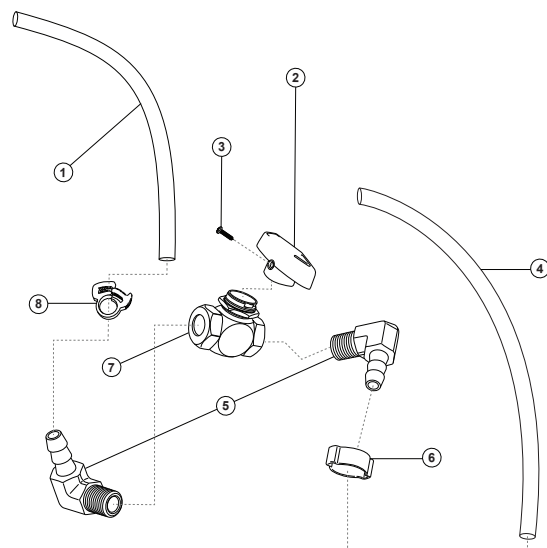

5.8 1250 PUMP ASSEMBLY

[P/N: PA1250]

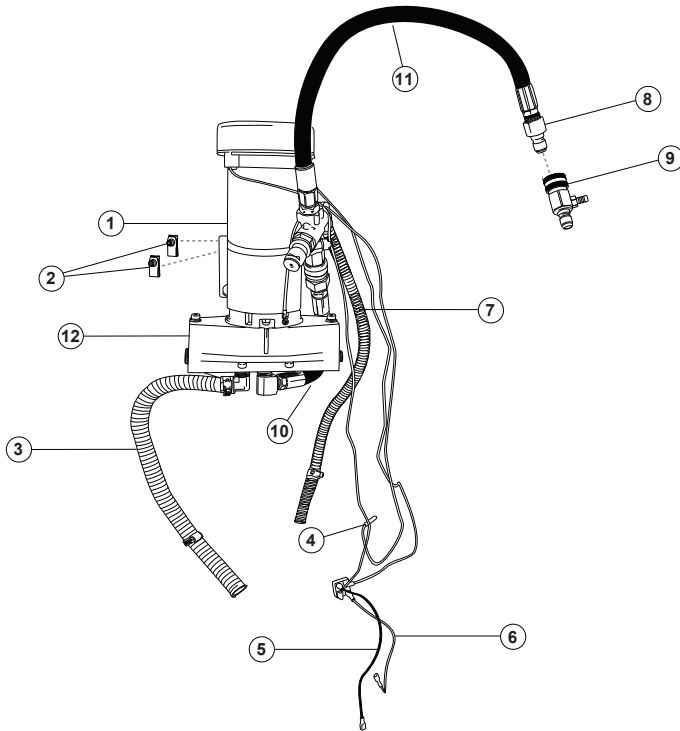

#	PART NO.	PART DESCRIPTION
1	PMA217	MOTOR ONLY
2	CSS08	5/16-18 U-NUT
3	WL1250	WATER LINE FOR 1250
4	CSS127	QUICK DISCONNECT TERMINAL
5	JWB	JUMPER WIRE BLACK 12 IN
6	JWW	JUMPER WIRE WHITE 12 IN
7	RL1750	RETURN LINE FOR 1750
8	CPS38	3/8 QD PLUG
9*	CPS12JQCS	QUICK CONNECT INJECTOR (SST)
10	CPS14B	PULSE HOSE SHORT
11	CPS14	PULSE HOSE LONG
12	PUMPSPARE217	PUMP ONLY

* Shown but not part of assembly

5.9 1250 QC PUMP ASSEMBLY

[P/N: PA1250B]

#	PART NO.	PART DESCRIPTION
1	P217AM-12B	PUMP ONLY
2	CSS08	5/16-18 U-NUT
3	WL1250	WATER LINE FOR 1250
4	RL1750	RETURN LINE FOR 1750
5	CPS38	3/8 QD PLUG
6*	CPS12JQC	QUICK CONNECT INJECTOR
7	CPS14B	PULSE HOSE SHORT
8	CPS14	PULSE HOSE LONG

* Shown but not part of assembly

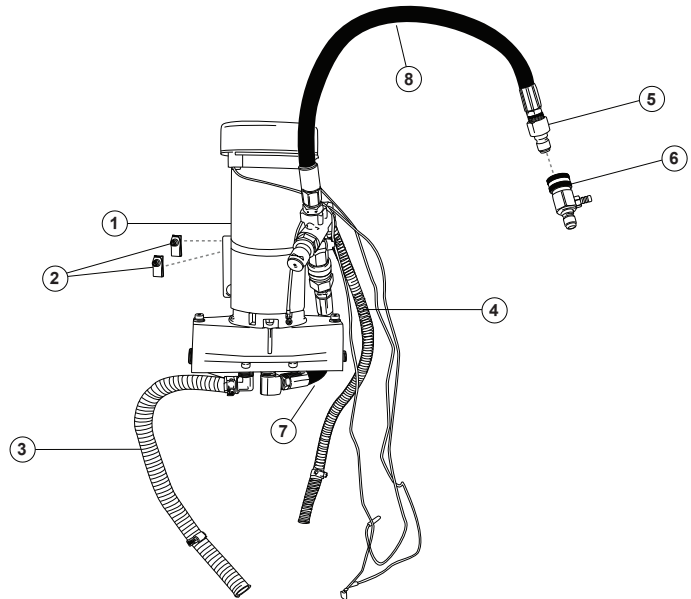

5.10 1200 QC VAC MOTOR ASSEMBLY

[P/N: VMA1200B]

#	PART NO.	PART DESCRIPTION
1	CSS203	HEX BOLT 1/4 20 X 1 1/4
2	CSS44	1/4 FLAT WASHER
3	CVM136V	2 STAGE VAC MOTOR 36V 1200
4	HFH16	HEPA FILTER HOSE 16 IN
5	CSS39	1 1/16-2 HOSE CLAMP
6	CSS11	NO 10 3/4 SELF DRILLING
7	CSS27	1/4 NYLOC NUT
8	VBRAK1	VAC MOTOR BRACKET KV1200 BATTERY
9	CSS153	1/4-20 U NUT
10	CSS08	5/16-18 U NUT
11	VMH27	VAC MOTOR HOSE

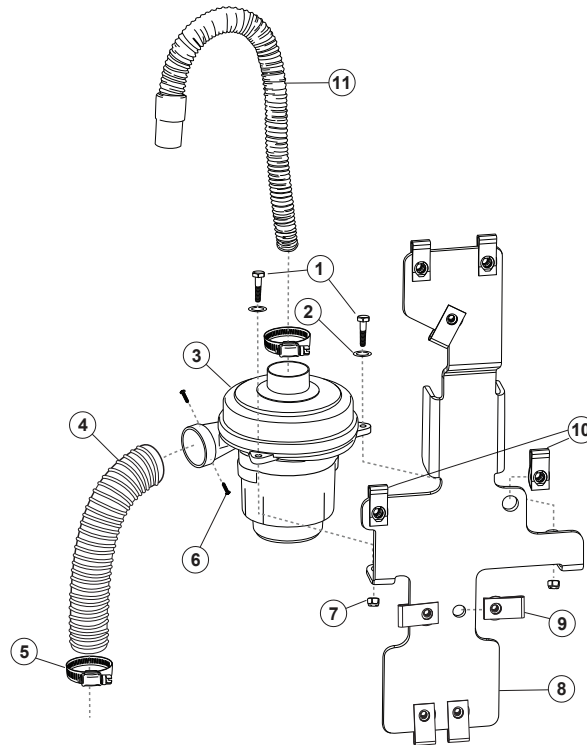

5.11 1200 VAC MOTOR ASSEMBLY

[P/N: VMA1200]

#	PART NO.	PART DESCRIPTION
1	CSS203	HEX BOLT 1/4 20 X 1 1/4
2	CSS44	1/4 FLAT WASHER
3	CVM1R	MOTOR FOR BUILDS
4	HFH16	HEPA FILTER HOSE 16 IN
5	CSS39	1 1/16-2 HOSE CLAMP
6	CSS11	NO 10 3/4 SELF DRILLING
7	CSS27	1/4 NYLOC NUT
8	VBRAK	VAC MOTOR BRACKET KV1200
9	CSS08	5/16-18 U NUT
10	VMH27	VAC MOTOR HOSE

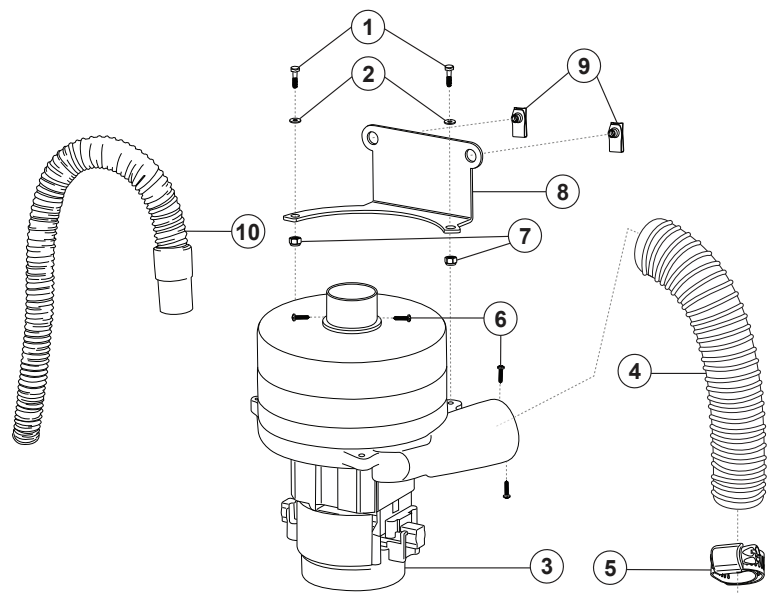

5.12 17001 VAC TANK ASSEMBLY

[WAXIE P/N: VTA17WAX, VTA17WAXV2] [ENVOY P/N: VT1700]

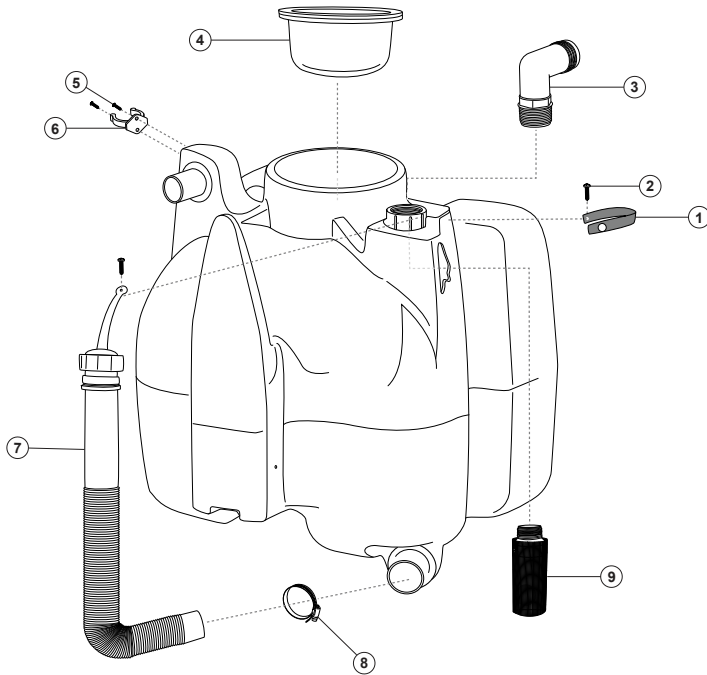

#	PART NO.	PART DESCRIPTION
1	SUBSS11	11 IN SNAP AND STRAP
2	CSS20	SNAP STUD
3	CSS144	1 1/4 NPT X 1 1/2 HOSE BARB
4	VLJHA	VAC LID, JUG HOLDER ASSEMBLY
5	CSS17	#8 FLAT HEAD SQUARE SCREW
6	CSS14	13 CLAMP, FOR TOOLS
7	DH25	26" X 1.5" DUMP HOSE 2" CUFF
8	CSS03	1 9/16 - 2 1/2 HOSE CLAMP
9	KZFLOAT	FLOAT SHUT OFF

5.13 17001 WATER TANK ASSEMBLY

[P/N: WTA17BK, WTA17BKV2]

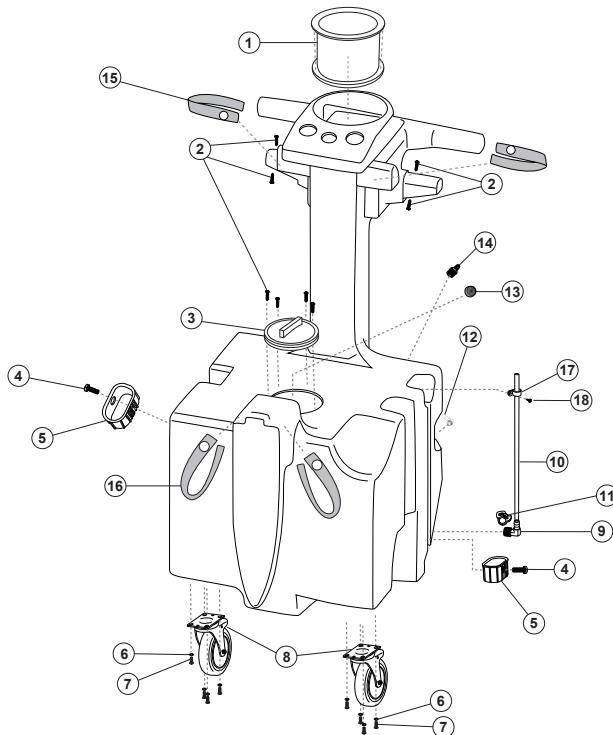

#	PART NO.	PART DESCRIPTION
1	VLJHA	VAC LID, JUG HOLDER ASSEMBLY
2	CSS17A	8 SST SCREW 3/4
3	LID4	LID WITH TETHER 4 1/2 IN
4	CSS88	1/4 20 X 3/4 SST SCREW
5	WDVTC	TOOL CUP
6	CSS133	5/16 SPLIT LOCK WASHER 300 SS
7	CSS132	5/16-18X1 BUTTON HEAD
8	CFS03	5 IN CASTER, MOUNTING PLATE
9	CSS143	3/8 IN 90 DEG BRASS BARB
10	ST15	SIGHT TUBE 14.75 IN 3/8 ID
11	CSS21	SNAP GRIP HOSE CLAMP SIZE D
12	CSS158	90 DEG BRASS 3/8 NPT X 1/2 HOSE
13	MFILT	MUSHROOM FILTER
14	CSS142	3/8 IN BRASS HOSE BARB
15	SUBSS4	4 IN SNAP AND STRAP
16	SUBSS6	6 IN SNAP AND STRAP
17	HWM003	CABLE CLAMP 7/16 BLACK
18	CSS11	NO 10 X 3/4 SELF DRILLING

5.14 17501 PUMP ASSEMBLY

[P/N: PA217, PA217B]

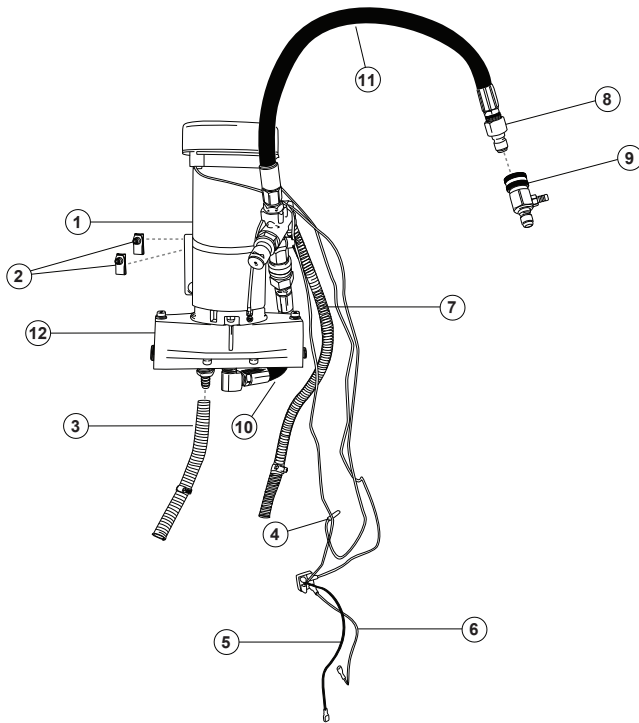

#	PART NO.	PART DESCRIPTION
1A	P217AM	PUMP SERIES 110V
1B	P217AMB	PUMP SERIES 36V
2	CSS08	5/16-18 U-NUT
3	WL1750	WATER LINE FOR 1750
4	CSS127	QUICK DISCONNECT TERMINAL
5	JWB	JUMPER WIRE BLACK 12 IN (CORDED ONLY)
6	JWW	JUMPER WIRE WHITE 12 IN (CORDED ONLY)
7	RL1750	RETURN LINE FOR 1750
8	CPS38	3/8 QD PLUG
9*	CPS12JQCS	QUICK CONNECT INJECTOR (SST)
10	CPS14B	PULSE HOSE SHORT
11	CPS14	PULSE HOSE LONG
12	PUMPSPARE217	PUMP ONLY

* Shown but not part of assembly

5.15 17001 VAC MOTOR ASSEMBLY

[P/N: VMA1700, VMA1700B]

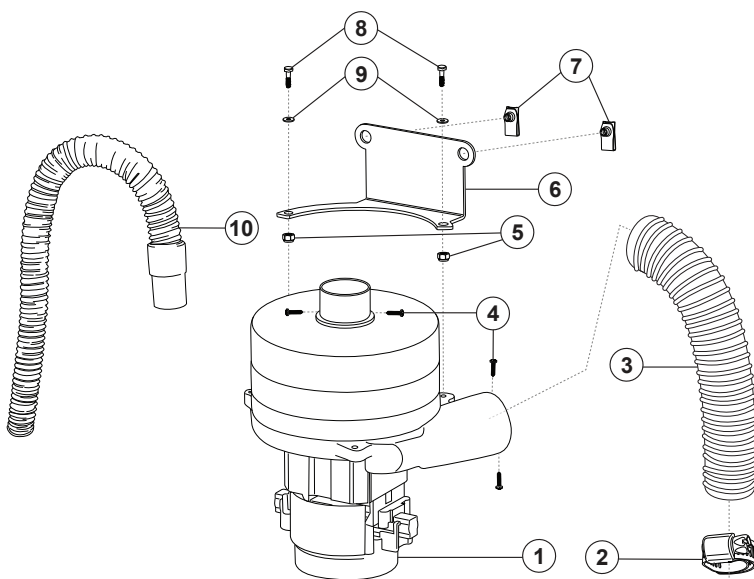

#	PART NO.	PART DESCRIPTION
1A	HEVM1	HIGH EFFICIENCY 120V VAC MOTOR
1B	CVM36V	HIGH EFFICIENCY VAC MOTOR 36V
2	CSS39	1 1/16 - 2 HOSE CLAMP
3	VEH19	VAC MOTOR EXHAUST HOSE 19 IN
4	CSS11	NO 10 X 3/4 SELF DRILLING
5	CSS27	1/4 NYLOC NUT
6	VBRAK4	VAC MOTOR BRKT KV1700
7	CSS08	5/16-18 U-NUT
8	CSS203	HEX HEAD BOLT 1/4 20 X 1 1/4
9	CSS44	1/4 FLAT WASHER
10	VMH27A	VAC MOTOR HOSE SHORT CUFF

5.16 27001 VAC TANK ASSEMBLY

[WAXIE P/N: VTA27WAX] [ENVOY P/N: VT2700]

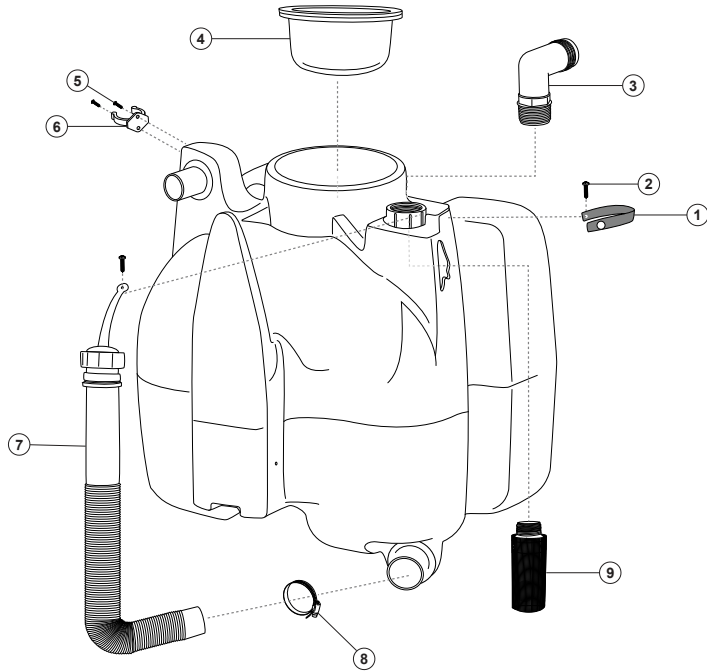

#	PART NO.	PART DESCRIPTION
1	SUBSS11	11 IN SNAP AND STRAP
2	CSS20	SNAP STUD
3	CSS144	1 1/4 NPT X 1 1/2 HOSE BARB
4	VLJHA	VAC LID, JUG HOLDER ASSEMBLY
5	CSS17	#8 FLAT HEAD SQUARE SCREW
6	CSS14	13 CLAMP, FOR TOOLS
7	DH25	26" X 1.5" DUMP HOSE 2" CUFF
8	CSS03	1 9/16 - 2 1/2 HOSE CLAMP
9	KZFLOAT	FLOAT SHUT OFF

5.17 27001 WATER TANK ASSEMBLY

[WAXIE P/N: WTA27BKV2] [ENVOY P/N: PT2700(CORDED), WTA27BKV2(BATTERY)]

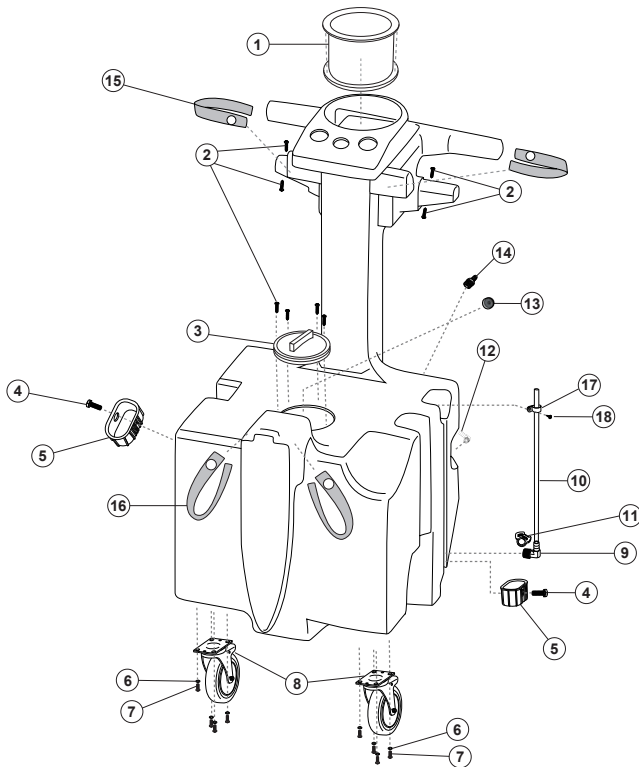

#	PART NO.	PART DESCRIPTION
1	VLJHA	VAC LID, JUG HOLDER ASSEMBLY
2	CSS17A	8 SST SCREW 3/4
3	LID4	LID WITH TETHER 4 1/2 IN
4	CSS88	1/4 20 X 3/4 SST SCREW
5	WDVTC	TOOL CUP
6	CSS133	5/16 SPLIT LOCK WASHER 300 SS
7	CSS132	5/16-18X1 BUTTON HEAD
8	CFS04	6 IN CASTER, MOUNTING PLATE
9	CSS143	3/8 IN 90 DEG BRASS HOSE BARB
10	HPST00	SIGHT TUBE 17.75 IN 3/8 ID
11	CSS21	SNAP GRIP HOSE CLAMP SIZE D
12	CSS158	90 DEG BRASS 3/8 NPT X 1/2 HOSE
13	MFILT	MUSHROOM FILTER
14	CSS142	3/8 IN BRASS HOSE BARB
15	SUBSS4	4 IN SNAP AND STRAP
16	SUBSS7	7 IN SNAP AND STRAP
17	HWM003	CABLE CLAMP 7/16 BLACK
18	CSS11	NO 10 X 3/4 SELF DRILLING

5.18 27501 PUMP ASSEMBLY

[P/N: PA217B]

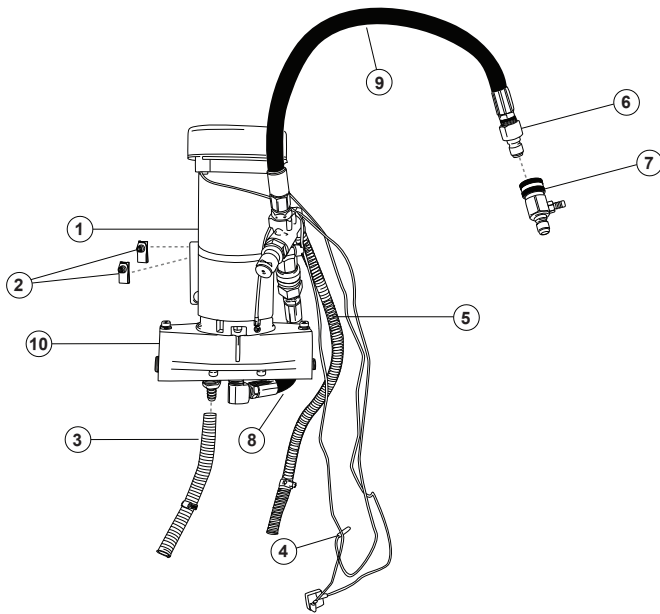

#	PART NO.	PART DESCRIPTION
1	P217AMB	PUMP SERIES 36V
2	CSS08	5/16-18 U-NUT
3	WL1750	WATER LINE FOR 1750
4	CSS127	QUICK DISCONNECT TERMINAL
5	RL1750	RETURN LINE FOR 1750
6	CPS38	3/8 QD PLUG
7*	CPS12JQCS	QUICK CONNECT INJECTOR (SST)
8	CPS14B	PULSE HOSE SHORT
9	CPS14	PULSE HOSE LONG
10	PUMPSPARE217	PUMP ONLY

* Shown but not part of assembly

5.19 27001 VAC MOTOR ASSEMBLY

[P/N: VMA27001B]

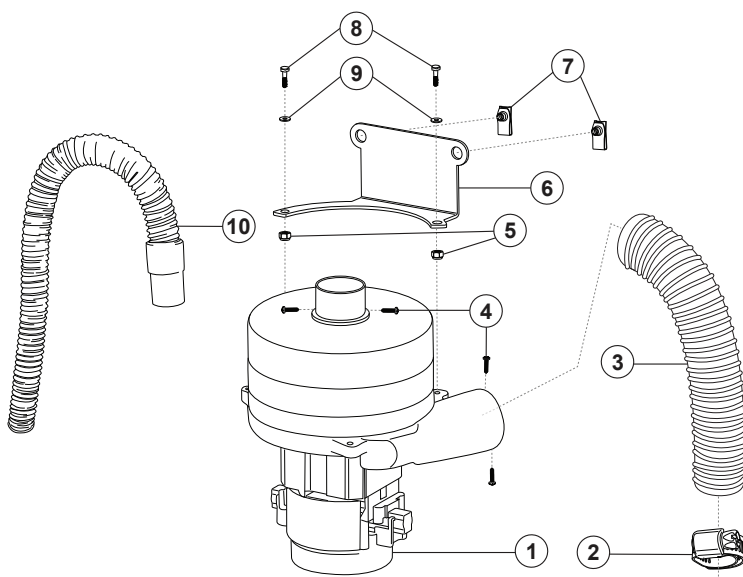

#	PART NO.	PART DESCRIPTION
1	CVM36V	HIGH EFFICIENCY 36V VAC MOTOR
2	CSS39	1 1/16 - 2 HOSE CLAMP
3	VEH19	VAC MOTOR EXHAUST HOSE 19 IN
4	CSS11	NO 10 X 3/4 SELF DRILLING
5	CSS27	1/4 NYLOC NUT
6	VBRAK4	VAC MOTOR BRKT KV1700
7	CSS08	5/16-18 U-NUT
8	CSS203	HEX HEAD BOLT 1/4 20 X 1 1/4
9	CSS44	1/4 FLAT WASHER
10	VMH34A	VAC MOTOR HOSE SHORT CUFF 34 IN

5.20 17501 AC BLACK BOX ASSEMBLY

[P/N: BBA17501S]

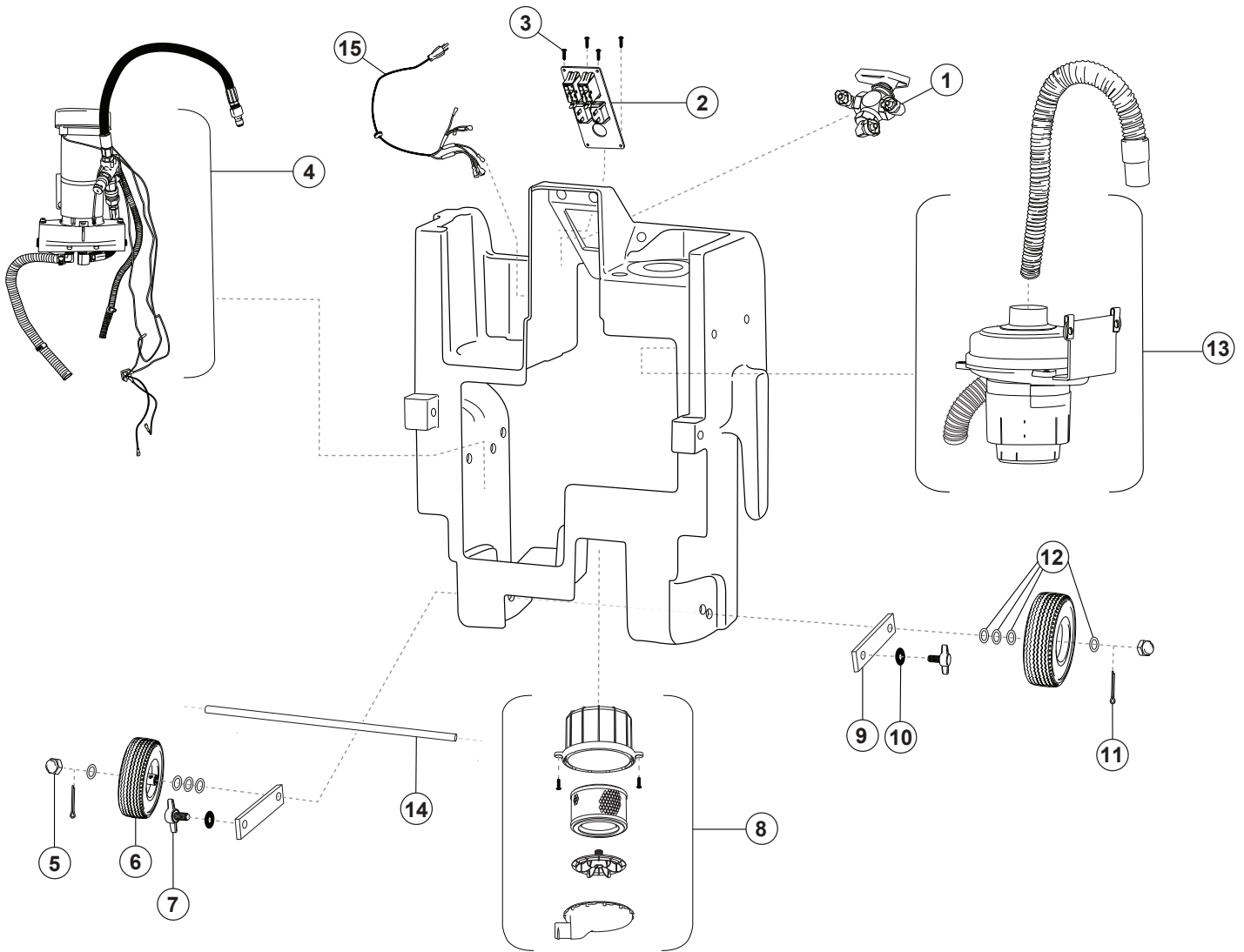

#	PART NO.	PART DESCRIPTION
1	VA3WS	VALVE ASSEMBLY 3 WAY SST
2	SPADC	SWITCH PANEL ASSEMBLY
3	CSS17A	#8 SST SCREW 3/4
4	PA217	PUMP ASSEMBLY COMPLETE KV1750
5	CSS01	1/2 IN PUSH CAP NUT
6	WHEEL8B	FLAT FREE TIRE 8 IN 1/2 HUB
7*	CSS156	3/8 X 3/4 T THUMB SCREW YELLOW

8	HEPAHA2	HEPA HOUSING ASSEMBLY
9	AXSTRAP	AXLE STRAP
10*	KMB16	3/8 SST FLAT WASHER
11	CSS72	COTTER PIN 1/8 DIA X 1 1/4 LG
12	CSS40	1/2 DIA WASHERS
13	VMA1700R	HE 120V VMA 1700
14	AX205	AXLE 20.5 IN X 1/2 DIA 303 SST
15	PCKV1A	POWER CORD MOLDED W/ GROMMET

* Shown but not part of assembly

5.21 QUICK CHANGE POWER PACK BLACK BOX ASSEMBLY

[P/N: BBA17501QCS, BBA27501QCS]

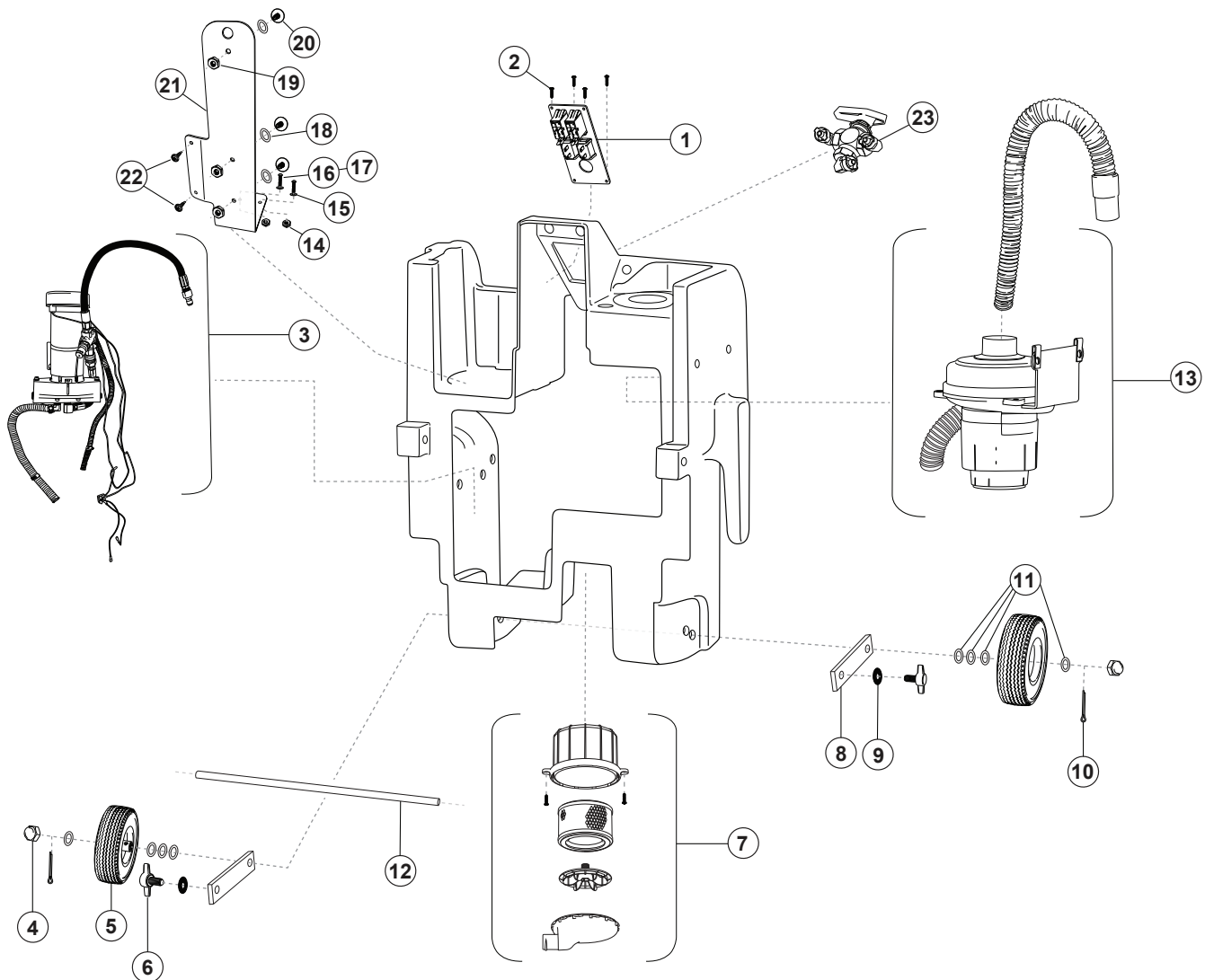

#	PART NO.	PART DESCRIPTION
1	SPADCB	SWITCH PANEL ASSEM DUAL CHEM BATT
2	CSS17A	8 SST SCREW 3/4
3	PA217B	PUMP ASSEMBLY COMPLETE FOR KV17501, KV27501
4A	CSS01	1/2 IN PUSH CAP NUT
4B	CSS43	5/8 PUSH CAP NUT
5A	WHEEL8B	FLAT FREE TIRE 8 IN 1/2 HUB
5B	WHEEL10	FLAT FREE TIRE 10 IN 5/8 HUB
6	CSS156	3/8 X 3/4 T THUMB SCREW YELLOW
7	HEPAHA2	HEPA HOUSING ASSEMBLY

12A	AX205	AXLE 20.5 IN 1/2 DIA 303 SST
12B	AX21	AXLE 21 IN 5/8 DIA
13A	VMA1700B	36V VAC MOTOR 1700
13B	VMA27001B	36V VAC MOTOR 27001
14	CSS74	10-24 NUT
15	CSS95	10 WASHER
16	CSS380	10-24 X 1 IN SST FLAT SCREW
17	CSS375	NO 10 18-8 SST SCREW
18	CSS109	1/8 IN SST RIVET BACKUP PLATE
19	CSS184	NUT #6-32
20	CSS183	SCREW #6-32 X 3/8 IN
21	NTCPBRAK	NTC POWER PACK BRACKET
22	CSS11	NO 10 X 3/4 SELF DRILLING
23A	VA3WBS	VALVE ASSEM. 3 WAY BATT SST
23B	VA3WB27S	VALVE ASSEM. 3 WAY BATT 27001 SST

5.22 17001 SWITCH PANEL ASSEMBLY

[P/N: SPADC]

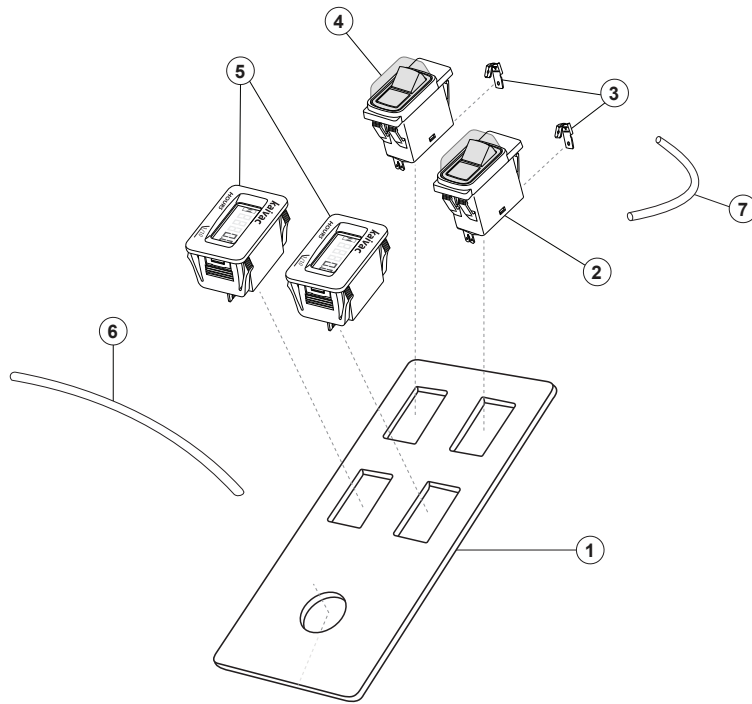

#	PART NO.	PART DESCRIPTION
1	SPDCSSB	SWITCH PNL DUAL CHEM FOR BREAKER SWITCH
2	5ACBS	5 AMP PUMP CIRCUIT BREAKER SWITCH
3	CSS123	QUICK CONNECT PIGGY BACK TERM
4	15ACBS	15 AMP VAC CIRCUIT BREAKER SWITCH WHT
5	HMETER	SNAP IN DIGITAL HOUR METER
6	JWW	JUMPER WIRE WHITE 12 IN
7	JWB5	JUMPER WIRE BLACK 5 IN

5.23 17501 BATTERY SWITCH PANEL ASSEMBLY

[P/N: SPADCB]

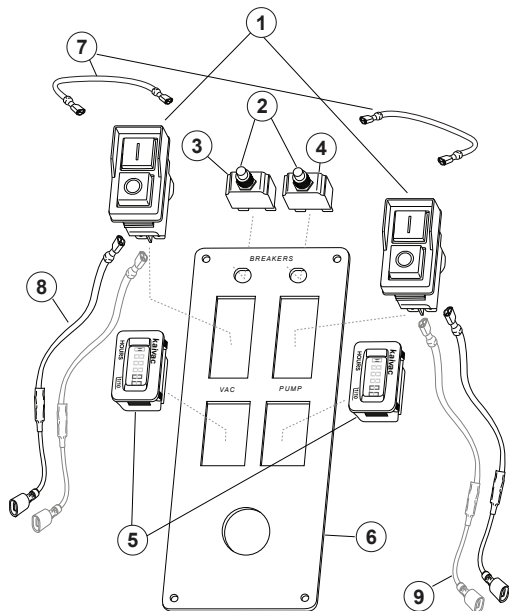

#	PART NO.	PART DESCRIPTION
1	18AEMS2	18A ELECTROMAGNETIC SWITCH HEAVY DUTY
2	UBBC	UNIVERSAL BREAKER BUTTON COVER
3	20ACBB	20A CIRCUIT BREAKER BUTTON
4	10ACBB	10A CIRCUIT BREAKER BUTTON
5	HMETER	SNAP IN DIGITAL HOUR METER
6	SPDCSSBB	SWITCH PNL SINGLE CHEM FOR BRKR SWITCH BATT
7	JWR5	12 GA. JUMPER WIRE RED 5 IN
8	JWB12	JUMPER WIRE BLACK 1/4 F TO BARE
9	JWR12	JUMPER WIRE RED 1/4 F TO BARE

5.24 17001/27001 VALVE ASSEMBLIES

[P/N: VA3WS, VA3WBS, VA3WB27S]

#	PART NO.	PART DESCRIPTION
1	CPS50S	3 WAY SST VALVE WITH VITON SEAL(INCLUDES KNOB)
2	CPS50B	BLACK KNOB 3 WAY VALVE
3	CPS68S	SST 90 DEG 1/8 NPT M X 1/4 BARB
4	CPS65	1/2 IN CLAMP
5A	SPH43	SWITCH PANEL HOSE 43 IN
5B	SPH34	SWITCH PANEL HOSE 34 IN
6	SPH18	SWITCH PANEL HOSE 18 IN
7	SPH9	SWITCH PANEL HOSE 9 IN

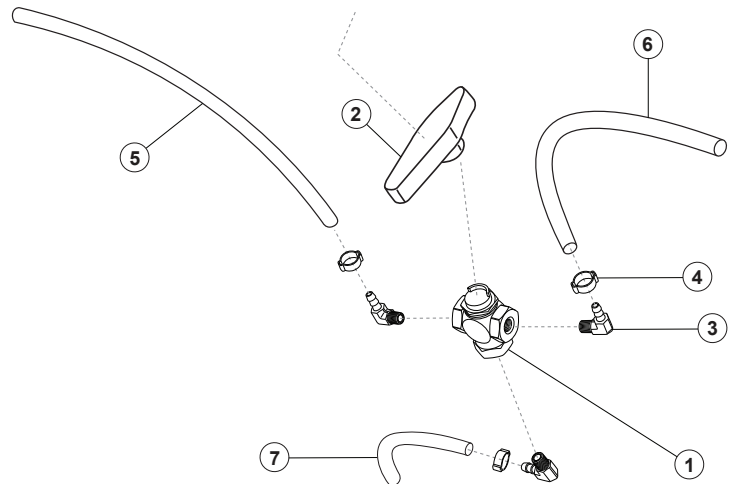

5.25 HEPA ASSEMBLY

[P/N: HEPAHA2]

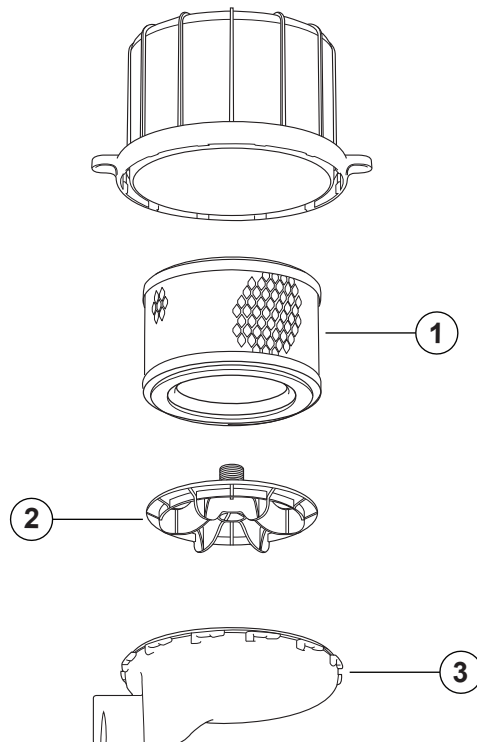

#	PART NO.	PART DESCRIPTION
1	HEPA	HEPA FILTER
2	FKEEP2	HEPA FILTER KEEPER
3	HCOVER	HEPA COVER



SUPPLIES + SUPPORT

We are a leading specialized distributor and solution provider focused on JanSan, foodservice, and industrial packaging. We are driven to make customers more successful and operations more sustainable and more productive.

We offer Supplies PLUS Support: Premium brands, expert advice, and exceptional customer experiences. Our 6,000 associates have a passion for delivering innovative solutions for the business challenges of today and tomorrow.

Together, we serve thousands of customers nationwide in end markets, including education, government, healthcare, hospitality, restaurants, building services, food packaging & processing, and grocery.

For more information on BradyPLUS, visit [BradyPLUS.com](https://www.BradyPLUS.com)

0324



Exclusively available through BradyPLUS and our Regional Distribution Brands
[BradyPLUS.com](https://www.BradyPLUS.com) + (877) 788-PLUS

© 2024 BradyPLUS