



RYDER CART FOR SANDERS OWNER'S MANUAL



Phone: 616.241.3040 | Fax: 616.241.3356
www.emackmfg.com | sales@emackmfg.com

© 2019 EMack Mfg

Important Notices

WARRANTY

EMack Manufacturing includes a one-year warranty for defects on material and workmanship affecting a machine's performance. For electrical components, including all switches, motor, and plugs, the warranty period is 90 days. Shipping is not included in the warranty. For any unit believed to be defective within warranty, write or call the dealer or distributor from which the machine was purchased. If you are unable to resolve to your satisfaction, please call EMack. Please give the seller's name, address, date and number of invoice, and describe the nature of the defect. If the unit was damaged during transit, file a claim with your carrier immediately! After the one-year warranty period has expired, charges will be assessed. An EMack-approved technician must perform all repairs within warranty period unless directed otherwise in writing. Failure to comply will result in a void on the unit's warranty.

ADDENDUM

EMack's liability under this warranty is limited to repair of the product and/or replacement of parts and is given to the purchaser in lieu of all other remedies, including incidental and consequential damages. There are no expressed warranties other than those specified herein. There are no warranties that extend beyond the description of the face hereof. No warranties, including but not limited to, warranty of merchantability, shall be implied. EMack accepts no responsibility for any direct or consequential damages or injuries, as EMack cannot control user's handling, end use, or effect of use.

ELECTRICAL

All electrical connections should be made by a qualified electrician. EMack can accept no responsibility for improper electrical connections. Improper connections can cause damage to you or your machinery. It is important for you, and the longevity of your machinery, that the proper electrical connections with the proper voltage be made. Also be sure the proper length and size of cord is used for your machinery. Improper cord size or length can damage the motor on your machine. If you are unsure, contact EMack for proper cord length and size. Failure to remove electrical plug from outlet before attempting service or maintenance could result in electrocution or severe injury. Always unplug machinery before servicing. Never leave the unit unattended while plugged in. Inspect all cords and equipment prior to use. Do not operate this machinery with broken or frayed cords.

WARNING!

Failure to follow all operating instructions and warnings can cause damage to your machinery or fatal injury to yourself or others.

- Do not operate this machine unless you are trained and authorized.
- Make sure extension cables are free of obstructions and in good working condition.
- Slow before turning and do not turn on slopes.
- Return the pedal to the neutral position and turn machine off before getting off machine.
- Do not attempt repairs unless you are trained and authorized.
- Do not let hands, arms, legs or feet extend beyond the dimensions of Ryder during operation.
- Riding sanders will tip over if not properly operated.
- Always do preventative maintenance before using the machine.
- Do not operate a faulty machine.
- Do not transport other people.

WHY WORK TWICE AS HARD?

Increase Efficiency with an EMack
Ryder!

Ryder Cart for Sanders



Aimed at helping industry professionals increase efficiency while reducing effort, the EMack Ryder Cart allows users to operate up to three sanders simultaneously, reducing sanding time and removing strain on the body. Single phase and 3-phase are available for 230V or 480V of power. For more information or to order, visit www.emackmfg.com or call 616.241.3040.

Operation

IMPORTANT

When transporting, the Ryder must remain vertical at all times. Avoid transporting machine on its side. Do not move your Ryder when attached to other machines. Use blocks and straps to secure the unit so it cannot roll, tip or bounce.

CAUTION

Damage to internal components will occur if BOTH hubs are not properly engaged prior to operation of the Ryder.

ELECTRICAL HOOK UP

Power is fed to the Ryder by a pig tail from the floor sanding machine. Be sure the sander is set up for Ryder use and all electrical cords and extensions are in good working order. The proper wire size is 14 gauge 4 wire for 3-phase. If you have any questions, please call your distributor.

Start Up



1. Verify BOTH hubs are unlocked. Make sure the oil level is at full "cold" level mark. **Use only SAE 30W non-detergent oil.**
2. Using your hand, make sure the foot pedal operates freely and returns to the neutral position. **The pedal can be moved to either the left or right side of the machine.**
3. With the sanding or buffing machine(s) hooked up to your Ryder according to the proper hook-up procedure, sit in the seat. Check your arm, leg and height distance to your sander(s) and controls. Make the necessary adjustments to the seat, linkage, and handles. Make sure everything is within comfortable reach.

4. Once comfortable, press start. Look at both hubs. There should be little or no rotation of the hubs. If there is excessive rotation, call your distributor.
5. Turn your Ryder off. Pull each hub out, rotate 1/8 turn, tilting the machine slightly and rotating the wheel until the hub locks in place. **Do not lock in the hubs with the machine running. Damage can occur.**
6. Sitting on the Ryder without your foot on the pedal, turn the machine on.
7. Then, gently press the toe of your shoe to the foot pedal to move forward. Press your heel to the pedal to move in reverse.



On the three-phase model, make sure your wheels rotate in the proper direction in accordance with the pedal. It is possible to reverse the direction with improper electrical hook-up. If your Ryder is operating backwards, press stop and exit the machine. Open the lid and switch the direction using the switch on the end of the electrical box. DO NOT SWITCH WHILE RYDER IS RUNNING! Also check the rotation of your sanders.

Operation

IMPORTANT

To reduce the chance of drum rubber separation with sanders having heavy-duty motors and weights, increasing speed and making more passes on the floor will lessen the chance of drum damage. Slower operation under these conditions can burn the finish, generate extreme heat and damage the drum rubber.

Maintenance

Check oil regularly. If the level is lower than the reservoir, add a high grade SAE30W non-detergent oil until filled to the cold level. Run for five minutes then recheck.

EQUIPMENT SPECIFICATIONS

Width- 16 ½ "

Length- 45"

Overall Height- 54"

Seat Height- 33 ½"- 37 ½"

Weight- 260 lbs.

Pulling capacity- 400 lbs.

Gearbox supporting capacity- 638 lbs.

Speed- 60 ft/min. infinite variable forward/reverse

Motor- 2 h.p. 230V

(Optional single phase 230V) (480 Convertible – Requires different electrical box)

Drive- hydrostatic

Gearbox type- worm gear

Rear wheels- 12' x 2 5/8 "

Front wheels: Dual set up poly/aluminum center 3 1/8" diameter X approx. 1 ½ " width

Frame – welded aluminum 3/16" – 3/8"

OPERATION

Initial Inspection

Please make sure you have read this owner's manual before operating the machine. If you lose your owner's manual, call (616) 241-3040 and we will make sure to distribute a new one to you.

Correct power supply must be confirmed before a qualified individual connects the unit. All Ryders are available in either three-phase or single-phase 220V operation. (They can be converted to 480V service with optional 480V electrical box.) DO NOT attempt to operate the Ryder on 480V without optional 480V electrical box. (sold separately)

Assembly

Your cord holder is the only part that will need to be installed upon delivery of your Ryder. Slide the small end into the pivoting bracket at the rear of your machine. Tighten the thumbscrews to secure the cord holder.

Follow the proper hook-up procedure for the equipment you will be attaching.

Verify that BOTH the rear wheel hubs are unlocked at this time.

Transportation & Cleaning

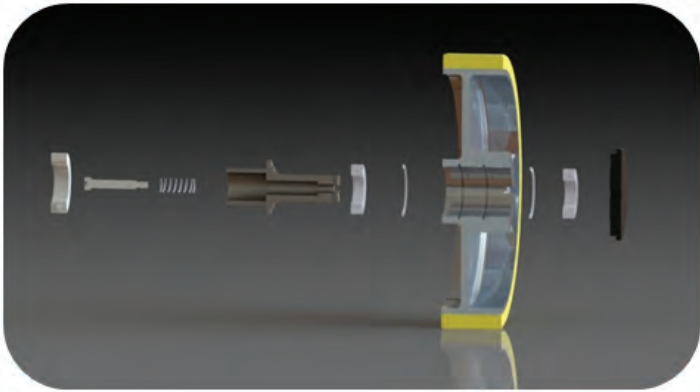

Transporting

Your locking hubs (102-006) are located in the center of each wheel. If the hubs are locked in place, you will need to disengage them. Pull the spring-loaded hub away from the machine and rotate 1/8 turn. Release the hub and it should not snap back in place, hub should now be in the locked out position. After performing this on both rear wheels, the machine should roll freely allowing you to easily push the Ryder.

Cleaning

Blow the dust off from the transmission cooling fins and transmission casing after every 12 hours of use. Do not tip machine more than 45 degrees from the upright position.

Perform a daily check of all cords, tires and equipment to ensure proper working order.

The Ryder should be cleaned regularly. The finishing process of wood floor creates wood dust that can build up over time inside your machine. This may cause overheating or excessive mechanical wear. Dust can be removed with an air nozzle. Eye protection is highly recommended. The following is a caution advisory by OSHA standards regarding wood dust.

1. Avoid dust contact with ignition source.
2. Sweep or vacuum dust for recovery or disposal.
3. Avoid prolonged or repeated breathing of wood dust in the air.
4. Avoid dust contact with eyes and skin.
5. First Aid: In case of contact, flush eyes and skin with water. If irritation persists, call a physician.

Equipment Refurbishing



EMack also offers equipment refurbishing for equipment used in the wood floor industry!

Attachment Hook-up

ATTACHMENT HOOK-UP

To attach your Ryder to specific equipment, any of the following pieces may be required. Please call for your specific Ryder questions.

100-017	Sander Connecting Rod	100-300-6	AL12 Sander Left Bracket
100-304-5	Hummel Connecting Rod	100-305-2	Galaxy Bracket
100-300-1	Dual Tow Bar	100-304-4	Hummel Bracket
100-300-5	AL12 Sander Right Bracket	100-300-1 EX	Dual Tow Bar - Extended

AL8 and 12 Drum Sanders

The parts needed for each of your AL8 and AL12 sanders are 100-300-5 and 100-300-6. Some sanders from EMack already have the right and left brackets installed. Depending upon whether you are connecting one or two sanders, you will need either a 100-300-1 or a 100-300-1 EX. 100-017 connecting rods are included with your Ryder.

Right and left rear brackets require drilling in the lower rear portion of your sanders' frames. With the pins on your brackets pointing upward, they must measure 8 ½" apart from each other after installation. The bottom of your brackets must measure 3 ¼" from the floor. If you have any questions, contact your distributor.

With the bumpers against a straight wall, line up your sanders with approximately two to six inches between the machines. Four inches is the industry standard. Make sure both units are on a level surface. Loosen the bolts connecting the tow bar ears to the tow bar. If you find it necessary to remove the ears, note the hole from which each was removed.

Attach the mounting ears to the sanders. Tighten ear bolts to the tow bar. Be sure each set of tow bar ears are at approximately opposite angles. (Tow bar ears are mounted on top of the tow bar) with the pins on your sanders. Center the bar so the ears on each sander are at approximate opposite angles. Tighten the ear bolts slightly. Place the springs on the sanders' pins. Slowly pull your sanders backward for a short distance. This will align them. Tighten the ear bolts completely now. The sanders are now ready to be connected to the Ryder. Put the sander connecting rods on the tow bar then add springs and clips. Back the sanders up to the Ryder and put on springs first, rods second, and clips third. The rods should appear parallel to the floor. Your leading machine (first machine engaged in cutting) should run its own cord through the cord holder. The other machine can be plugged directly into the front of your Ryder to complete the connections.

Galaxy

Galaxy sanders can be attached in the same manner as the AL12 machines. The only difference is they require a 100-304-4 bracket on each side of each sander instead of 100-300-5 and 100-300-6. On Clarke/Galaxy models, the brackets are installed with pins pointing down.

It may be necessary to shorten the tow bar when using eight-inch sanders in order to sand closer to the walls. If you have any questions, call your distributor for procedure details.

Hummel

Hummel sanders require the use of longer connecting rods. (100-304-5) Remove the carry handles from the lower rear part of your Hummel's frame. Replace these with a 100-304-4 bracket on the right and left of each sander. The connecting pin should point upward. The rest of the connection procedure is similar to the AL12 hook-up.

Troubleshooting Instructions

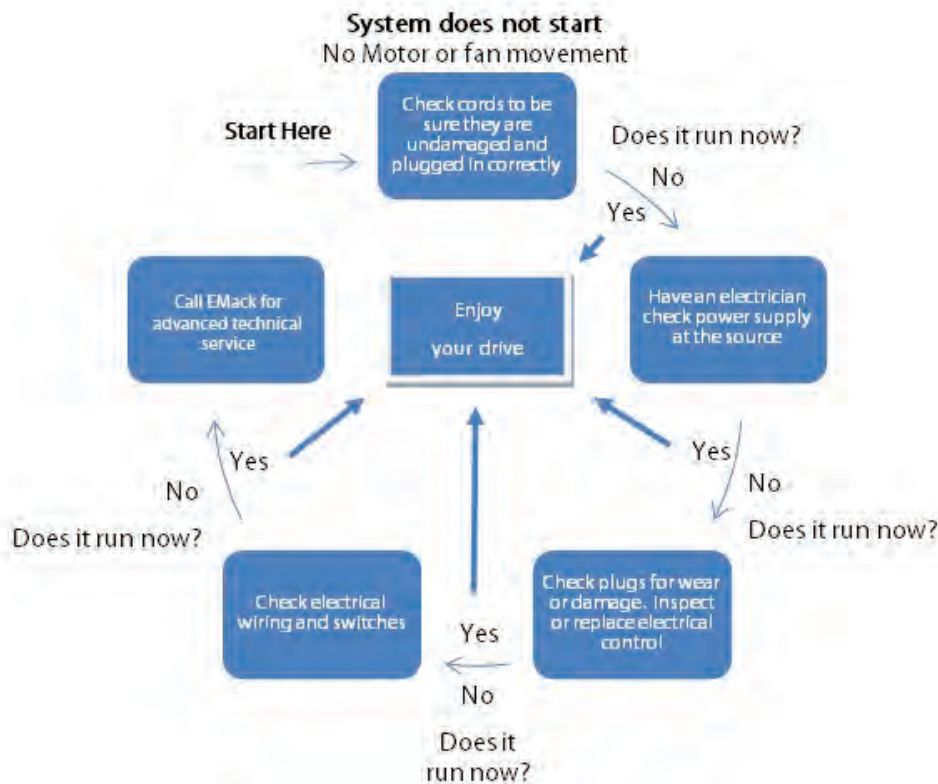

This fault-logic troubleshooting section is designed as a diagnostic aid in locating and resolving Ryder issues and problems. If you encounter a problem you can not correct, call one of the expert equipment technicians at your distributor. The recommended safety equipment is listed below for maintenance.

- Dust masks
- Ear plugs
- Safety goggles

If your equipment is having trouble with starting, please refer to the diagram above. If your equipment is having trouble with moving, refer to the diagram to the right. If your equipment does not move and the process pictured on the right does not resolve your issues, check the oil level. Fill to the proper level with SAE 20W or 30W non-detergent oil. An oil leakage is symptomatic of other problems. If you regularly add oil, please contact your distributor for service.

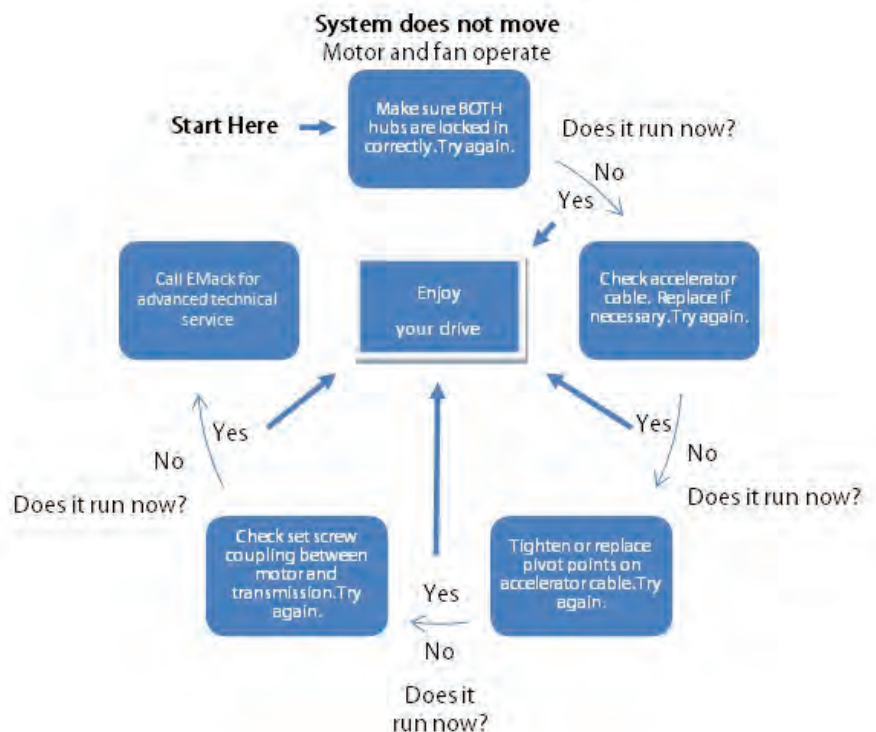

Parts View - Front and Top

Expanded Parts View:

Front

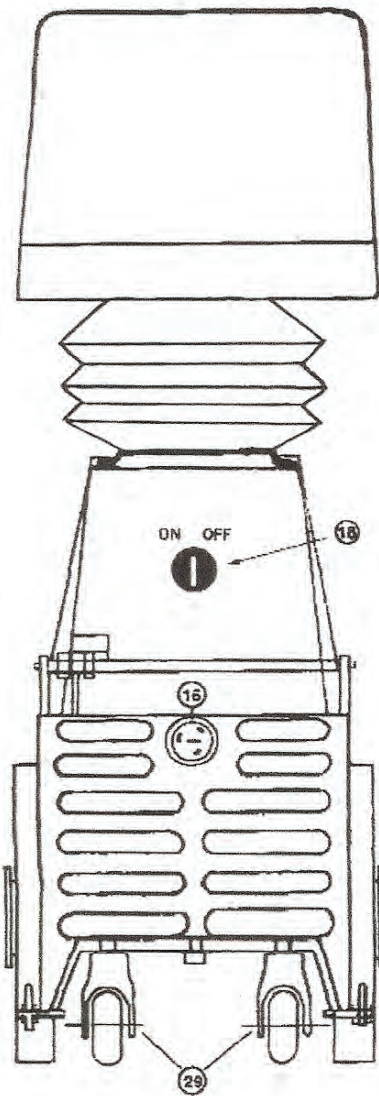

Top

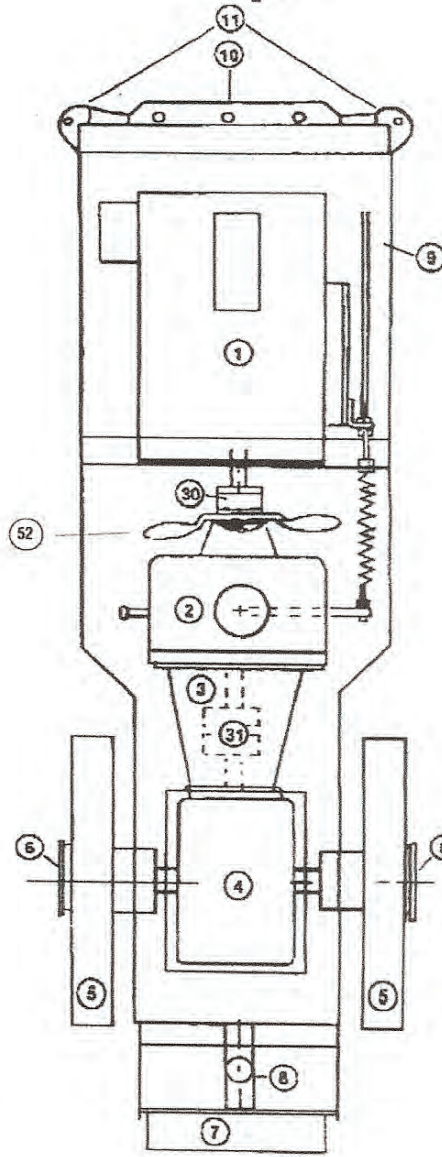

No.	Part #	Description
1	103-001	Electric Motor
2	102-011	Hydraulic Transmission
3	102-020	Rear End
4	102-002	Urethane Rear Wheels
5	102-006	Locking Hubs
6	100-051	Bumper Bracket Replacement
7	100-045	Cord Holder Pivot
8	100-021	Throttle Cable
9	100-020	Hook Up Pins
10	100-001	Hydraulic Seat
11	100-050	Seat Box
12	100-012	Main Frame
13	922-2725	AC Plug (three phase)
13	922-2625	AC Plug (single phase)
14	100-088	Start/Stop
15	100-032	Front Wheels
16	103-010	Motor to Transmission Coupling
17	102-026	Axle
18	100-052	Quick Disconnect
19	103-011	Ryder Electrical Box
20	102-013	Trans to Rear End Coupling

Parts View - Side

Diagram 2

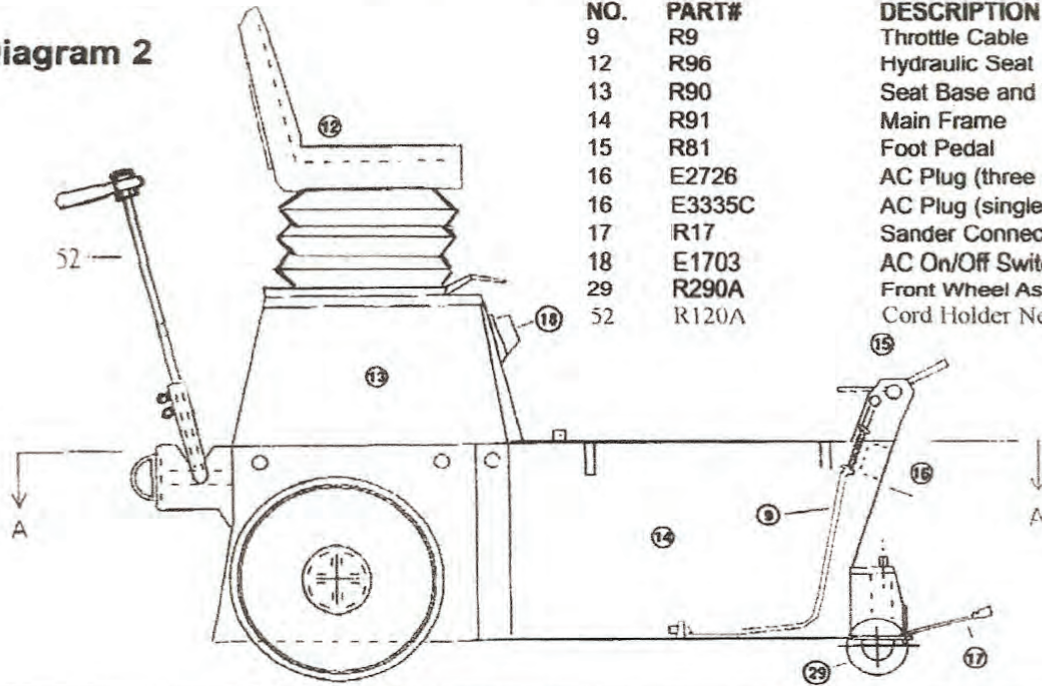

NO.	PART#	DESCRIPTION	QTY.
9	R9	Throttle Cable	1
12	R96	Hydraulic Seat	1
13	R90	Seat Base and Tool Box	1
14	R91	Main Frame	1
15	R81	Foot Pedal	1
16	E2726	AC Plug (three phase)	1
16	E3335C	AC Plug (single phase)	1
17	R17	Sander Connecting Rods	2
18	E1703	AC On/Off Switch	1
29	R290A	Front Wheel Assembly	1 or 2
52	R120A	Cord Holder New Style As	1

Wheel Assembly

NO.	PART#	DESCRIPTION	QTY	NO.	PART#	DESCRIPTION	QTY
6	R6	Locking Plate	2	24	R24	Hub	2
19	HSR11/8	Exterior Snap Ring	2	25	HBA3/816X3/4	3/8" x 3/4" Allen Head Bolt	2
20	HSR123/16	Interior Snap Ring	2	26	HKS1/4	1/4" Key	2
21	B6006	Bearings	4	27	R27	Spring	2
22	R22	Spacer	2	28	HBS3/8X2	3/8" Shoulder Bolt	2
23	R23	Aluminum Wheel	2	Entire Assembly		R5	

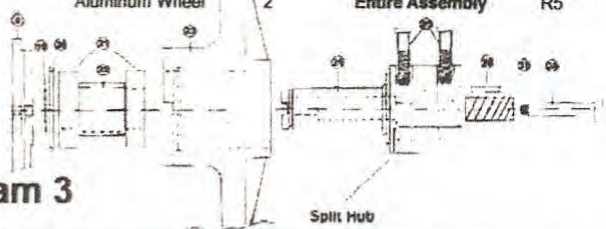
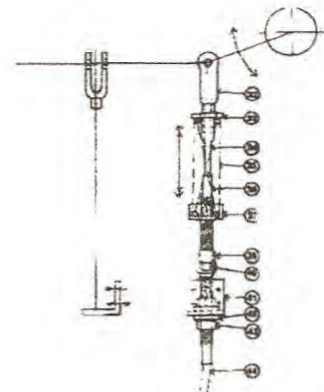

Diagram 3

Diagram 4



Throttle Assembly Cable

NO.	PART#	DESCRIPTION	QTY
32	R32	Clevis	1
33	R33	Upper Adjusting Spring Holder	1
34		Inner Rods	1
35	R35	Centering Springs	1
36		Outer Casing	1
37	PIC1/4	Pinch Collar	2
39		Dust Boots	2
40		8 degree Flex Joint	2
41	R41	Upper Bracket	1
42	HWL7/16	7/16" Lock Washer	4
43	HN7/16/20	7/16" - 20 Adjusting Nut	4
44	R44	Flex Casing	1
45	R41	Lower Bracket	1
46	R46	Lower Adjustable Spring	1

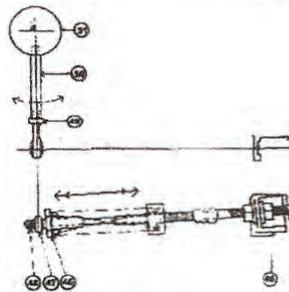

NO.	PART#	DESCRIPTION	QTY
47	SVSPM4	1/4" x 1/4" - 28 Rod Ends	1
48	HNI10	10 - 32 Jam Nuts	2
49	HNI1/4	1/4" - 28 Jam Nut	1
50	R50	Transmission Pivot Rod	1
51	R51	Transmission Slug	1

Pre-Shipment Checklist

We Take Pride in Our Work. The Following Checks Have Been Completed Prior to Shipment:

Customer: _____

Serial #: _____

Date of Manufacture: _____

Motor: _____ Single Phase 3 Phase

- | | | | |
|-------------------|--------------------------|------------------|--------------------------------|
| Fan Assembly | <input type="checkbox"/> | Lid Latches | <input type="checkbox"/> |
| Rear End | <input type="checkbox"/> | Voltage | <input type="checkbox"/> |
| All Fluids | <input type="checkbox"/> | Forward RPM | <input type="checkbox"/> _____ |
| Vibration | <input type="checkbox"/> | Reverse RPM | <input type="checkbox"/> _____ |
| Seat | <input type="checkbox"/> | Wheels | <input type="checkbox"/> |
| Cord Holder | <input type="checkbox"/> | Body | <input type="checkbox"/> |
| Accelerator Pedal | <input type="checkbox"/> | Arm & Head Rests | <input type="checkbox"/> |
| Lock Outs | <input type="checkbox"/> | Serial # Stamped | <input type="checkbox"/> |
| Small Parts | <input type="checkbox"/> | | |

Tested By: _____

QC By: _____

Packaged By: _____

Ship Date: _____

Comments: _____





Phone: 616.241.3040

Fax: 616.241.3356

www.emackmfg.com

sales@emackmfg.com